

FluoroFlow® PTFE-Expansion Joints

FFB Type: 1" NB – 10" NB with XHD*-Liner

FFB type: 12" NB – 42" NB in XHD*/HD**

FFAB type: 1 ½" NB – 20" NB 16 bar(g) Short Series

FFAB type: 1 ½" NB – 16" NB 16 bar(g) Long Series

FFAB type: 1 ½" NB – 20" NB 25 bar(g)

PTFE Expansion Joint with metal reinforcement

*** PTFE wall thickness "Extra Heavy Duty**

**** PTFE wall thickness "Heavy Duty**

FluoroFlow® PTFE-Expansion Joints**Essentials****Introduction**

The engineering design of FluoroFlow® PTFE-Expansion Joints (Series FFB) dates back as long as 40 years with the purpose to compensate thermal expansion in piping components in common with the protection of fragile process equipment such as graphite, plastic or glass possibly associated with vibration hazards. PTFE-Expansion Joints are particularly suitable for corrosive, high purity or hot applications.

CRP as manufacturer owns some unique manufacturing processes based upon the use of paste extruded PTFE besides multi-ply PTFE-tubes of their own manufacture followed by a proprietary convolution process. These have been independently tested by the internationally recognised safety and quality group TÜV, undertaking innovative long-term pressure increase testing.

The Product Family

Twenty different nominal sizes range from DN25/1" to DN 1050/42". They are manufactured in two types of materials virgin PTFE and static dissipating PTFE. FluoroFlow® Bellows in sizes DN 25/1" to DN 250/10" are available in extra heavy duty only. For larger diameters there is a choice of two wall thicknesses – a heavy duty (HD) and extra heavy duty (XHD). The expansion joints can be manufactured with two up to ten convolutions. However, this is just the standard product. The flexibility of the manufacturing method is such that many special configurations can be produced to meet specific customer requirements.

For products requiring a higher pressure rating not possible with PTFE alone, we have our range of armoured PTFE-Expansion joints (FFAB) where the PTFE is surrounded by a high pressure metallic shell.

HiPerFlon®

HiPerFlon® is a second generation paste extruded High Performance PTFE. HiPerFlon® has the greatest mechanical properties and lowest permeation rates of PTFE materials and as such provides high pressure ratings, long lifetime, low maintenance costs and consequently the lowest cost of ownership.

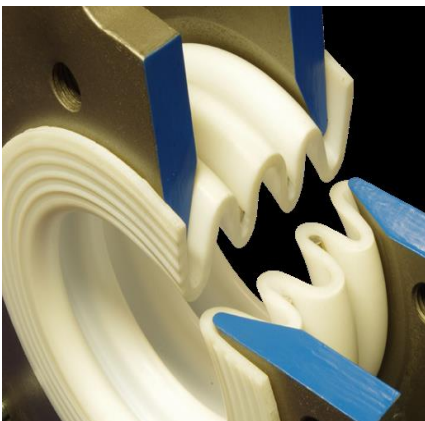
The Manufacturing Process

CRP uses virgin paste extruded or virgin multi-ply PTFE-tubes of their own manufacture to guarantee the highest quality from the beginning up to the concluding production process. A unique convolution process undertaken at very high temperatures (>300 °C), combined with additional material to compensate for the length from straight to convoluted, provides a uniform PTFE wall thickness and a stress-free material in a thermally locked bellows shape. This process has a significant influence on product lifetime performance.

Design and Type Testing

A key consideration in expansion joints performance is the temperature and pressure that the items will withstand for extended periods of time. There is no ASME, DIN or other global standard for the design of expansion joints. Most of CRP's competitors just use a simple burst pressure test at ambient temperature to create the comprehensive pressure/temperature curves in their catalogues, sometimes with safety factor of less than 3. A safety factor is defined as the ratio of burst pressure to allowable operating pressure. Bursting pressure tests, although a key indicator, cannot fully define a bellows performance as a burst pressure test has a duration of 10 to 20 seconds and is unable to replicate the effect to deformation of the bellows through creep. Therefore, CRP has developed a much more comprehensive approach to testing as follows:

FluoroFlow® PTFE-Expansion Joints

Performance Tests

Burst Pressure Test

Bursting pressure tests are used only for the determination of pressure rating at ambient (20 °C) temperature. At this temperature CRP has adopted a safety factor of 6 for expansion joints up to DN 200/8" and a safety factor of 4 for the larger diameters.

Pressure Increase Test

In addition to the bursting pressure tests, innovative pressure increase tests have been undertaken successfully at 100 °C, 150 °C and 200 °C by TÜV. These unforgiving tests slowly increase the delivered pressure to the bellows at high temperatures, encouraging the PTFE material to flow and creep as in service. The pressure increase test results confirm the outstanding creep resistance of the FluoroFlow ® Bellows provided by the unique convolution process.

Internal Pressure Long Term Creep Test

FluoroFlow® Expansion Joints have successfully passed an internal Pressure Creep Test (similar to EN ISO 9080) by TÜV at 150 °C. 14 expansion joints have been tested in total and two of them remained under pressure at 150 °C in the oven for over one year. This confirms the long-term creep resistance even at high temperatures and pressures.

Lifetime Assurance

Based on the pressure/temperature limits from these tests, CRP has determined the pressure/temperature curves for the FluoroFlow ® PTFE- Expansion joints to have a residual safety factor of 2 after more than 10 years in operation.

International Standards

The full dimensional range complies with the actual Pressure Equipment Regulations (Pressure Equipment Directive 2014/68/EU) and is provided with a CE-Declaration of conformity. PTFE armoured expansion joints for high pressure performance are designed according to the EJMA international standard. The business is third party accredited to ISO 9001:2015.

Product Testing

Applied materials are fully traceable. Expansion joints tubes undergo mechanical and dimensional tests following manufacture. PTFE sintering and convolution transforming process are undertaken using calibrated ovens with precise temperature control. Independent process checks are undertaken using infra-red thermometry. In-process visual inspection on the PTFE tubes is undertaken and combined with a hydrostatic test and further visual inspection of the finished product completes the product verification. Certification is available, if required, to reassure the customer on materials of construction, process control and product testing.

Operating Temperatures

The standard operating envelope for the product is 0 °C to 200 °C, but expansion joints can be supplied for temperatures outside this envelope.

FluoroFlow® PTFE-Expansion Joints

Further Particulars

Special Expansion Joints

Many customized versions are available, including expansion joints with extended flares, reducing make-ups (different flange sizes), hinged bellows, lateral expansion joints, dual containment expansion joints, versions with special neutral lengths and modifications with special PTFE wall thicknesses. Internal vacuum support rings can be provided in exotic metals or PTFE lined and flanges can be manufactured in various other metals. Expansion joints with electrically isolating tie rods are likewise available upon necessity-



Safety Shields

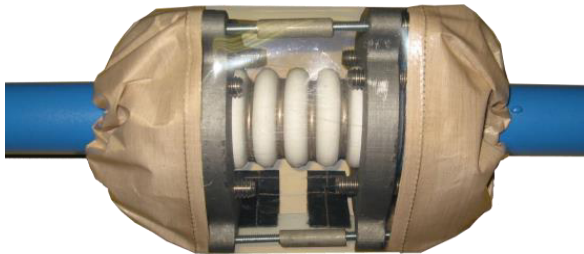

Following guidance from the European Pressure Equipment Directive 2014/68/EU and international insurers, we strongly recommend the use of safety shields around each expansion joint. Because of its nature, the expansion joint represents the weakest part of a piping system and safety shields can assist in mitigating risk to operators and environment.

Smoothbore Sleeves

If handling media at high velocities or with entrained solids we suggest you consider using smoothbore sleeves. These are manufactured from PTFE and provide additional protection to the expansion joints for abrasive duties as well as minimising the potential build-up of solids in the convolutions. As standard these are supplied as a loose fit to avoid the sleeve constraining the movement. However, a tight fit is also available. As standard the sleeve is sized to protrude just beyond the end when it is at maximum axial length, but this can be specified at the time of order.



Design and Piping Layout

Prior to specifying the expansion joints, it is necessary to produce a piping layout with correct pipe supports and an exact specification of the extended movements, irrespective of whether they are to be used for thermal compensation or the protection of fragile equipment made of glass or graphite. Expansion joints cannot support forces either from the weight of the piping components or from the liquid inside the pipes.

Effective Area and Spring Rates

The effective area and the spring rates have a significant influence upon the stress calculations for the piping system. Please find the relevant data on the individual pages for each dimension. For the influence of temperature upon spring rates please consult the conversion table overleaf.

FluoroFlow® PTFE-Expansion Joints

Constructional Details

Temperature in °C	Correction Factors (TCF)
20	1,00
80	0,65
120	0,50
150	0,40
200	0,30

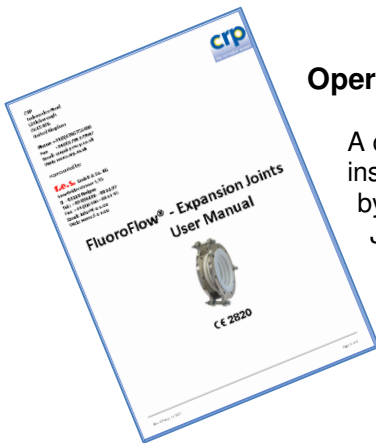

Operating and Installation Instructions

A comprehensive user manual is typically added to shipments of expansion joints. These instructions can also be downloaded from our website (www.f-e-s.eu) or can be sent out by email. It is critical that these are referred to the correct installation of PTFE-Expansion Joints.

Key Product Features

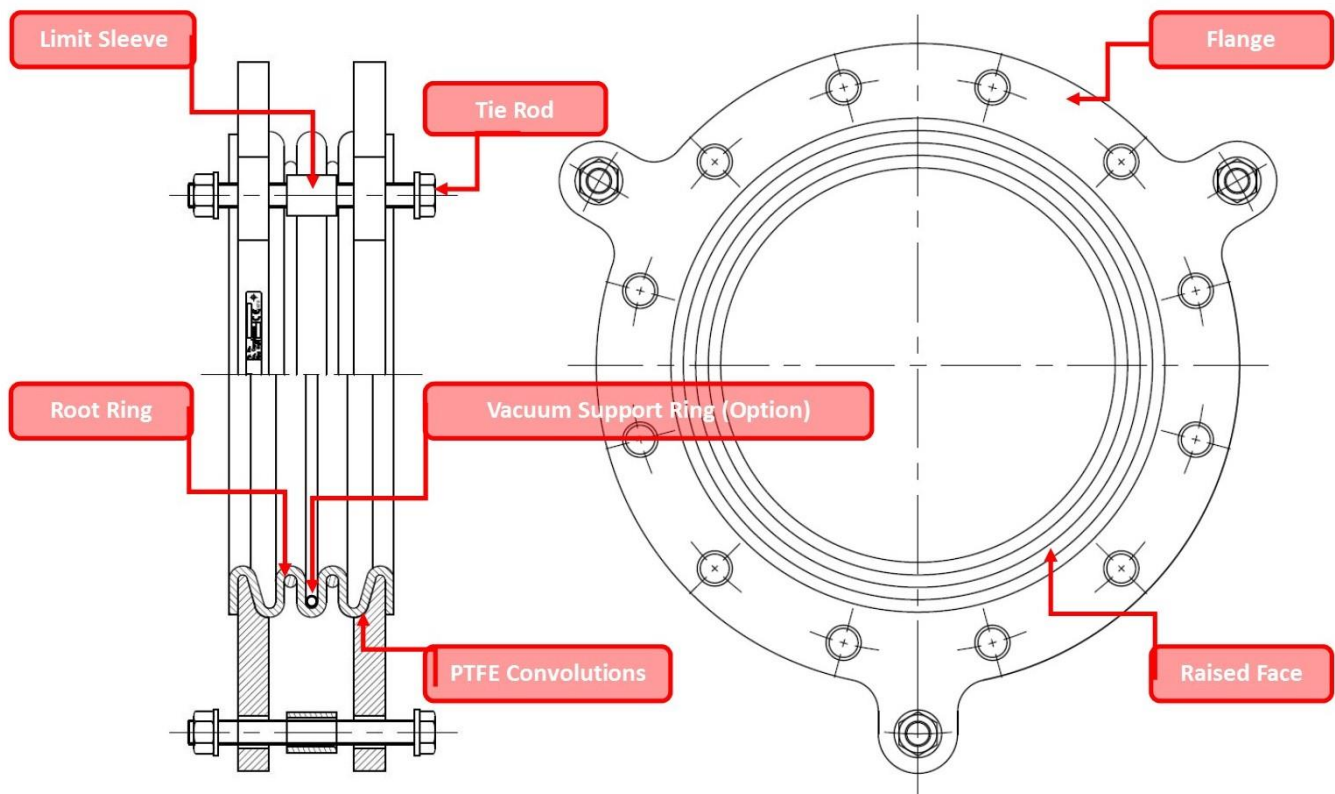

FluoroFlow® PTFE-Expansion Joints

Constructional Details

Flanges

Flanges for expansion joints are available to all of the international flange standards including ASME Class 150 and 300 and DIN PN 10 and 16. As standard the flange connection drillings are drilled either UNC for ASME or metric for DIN. Flanges are painted in an ultra high temperature paint in a silver finish. It is worth noting the internal flange profiling that assists the first convolution in minimising any stress generated by the flange.

PTFE Convolutions

The number of convolutions is key to the range of movement provided by the expansion joints – the more convolutions the greater the range of movement. However, the compromise is that both pressure and vacuum performance are reduced as the number of convolutions increases (see diagram).

In sizes above DN 250/10" there is the option of Heavy Duty (HD) or Extra Heavy Duty (XHD) make-up. The additional wall thickness of the XHD product provides an improved temperature and pressure range. Up to DN 250/10" XHD is the standard product.

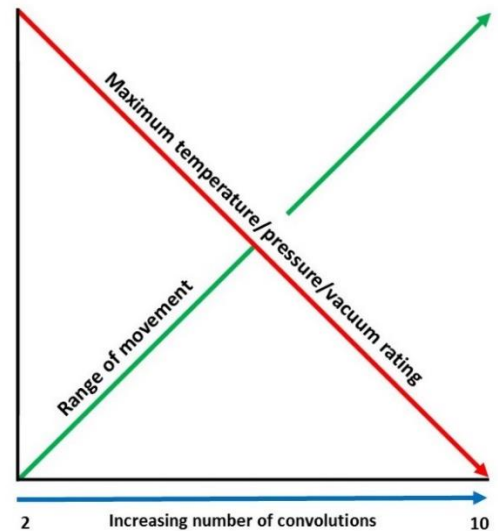

Root Rings

Root rings serve to provide support for the PTFE which is a mechanically weak material especially when hot. These sit at the base of each convolution. They are supplied in stainless steel as standard but can be manufactured in specific metals where required – for example to avoid the potential for stress corrosion cracking in hydrochloric acid service.

Tie Rods

These prevent the expansion joints from exceeding their maximum allowed movements. They arrive factory set at the maximum allowable extension as detailed on the data label. The tie rods have been sized to cope with the maximum pressure thrust that can result from internal pressure in the expansion joints, both in operation and during test. However, tie rods are not designed to cope with external loads applied to the bellows by the adjacent pipe work due to circumstances such as pipe work misalignment, failure of anchors etc.

Limit Sleeves

These prevent damage to the convolutions by curtailing the expansion joints from being compressed below the minimum allowable axial length.

Anti-Snake Rings



When the number of convolutions exceeds five we would recommend one or more anti-snake rings. These are mounted on the outside of the expansion joints, replacing and serving the role of the root ring, but also tying into the tie rod to prevent the expansion joints squirming under high temperatures and pressures.

FluoroFlow® PTFE-Expansion Joints

Identification

Vacuum Support Rings

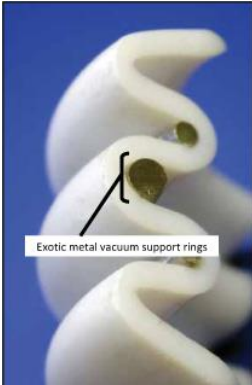

Internal vacuum support rings are available for larger expansion joints where they have a low or no vacuum performance. They will enable the bellows to work under full vacuum. These rings fit inside the bellows convolutions, so are exposed to the process. They are available either PTFE lined on the outside, or in various exotic metals. They may reduce movements of expansion joints, so please consult with us.

Data Labels

There are three or four data labels present on the expansion joint flanges to carry as much information about the items as practical. However, more information is available in the catalogue, or by reference to f.e.s., quoting the part number and serial number references.

The diagram shows a rectangular data label with the following text and callouts:

- 1: **FLUOROFLOW** (Product family)
- 2: Pt. No. 5723-41-010030 (CRP part number)
- 3: No. Convolutions 3 (Number of convolutions)
- 4: Ring Mat'l HC276 (Material used for the root rings)
- 5: CE 2820 (CE mark and notified body number for compliance with the PED)

Additional text on the label includes: **crp**, tel:+44(0)1706756400, web:www.crp.co.uk

1. The product family is referred to as FluoroFlow® Expansion Joint or “FFB”
2. The CRP part number
3. The number of convolutions
4. The material used for the root rings
5. Our CE- mark and notified body number for compliance with the PED (Pressure Equipment Directive)

The diagram shows a rectangular data label with the following text and callouts:

- 1: Flange Type DIN PN 10
- 2: Drillings M 20
- 3: Size DN 150

1. The flange type
2. The size and thread type for the drillings
3. The expansion joints nominal size or in case of reducing make-up, the flange size at each end

FluoroFlow® PTFE-Expansion Joints

Type of Movements

Temp °C		Press barg		Length mm		
-10	25	-1	8	Min	Neutral	Max
	200	0	2,8	60	85	110

Date: 08/16
S/N: 101623

1. Month and year of manufacture
2. Two rows of temperature and pressure information. In this example showing the performance at -10°C to 25°C and 200°C. There is not always enough room to show the maximum temperature which can cope with full vacuum, nor provide intermediate data. Reference to the data sheets in this catalogue can provide more information.
3. The minimum, neutral and maximum length for axial travel
4. A unique serial number for the item

Type of Movements

A key attribute of expansion joints is their ability to move in response to stress placed upon them by the equipment to which they are mounted, whether such stresses are generated by expansion and contraction or plant vibration. There are three directions of movement for which an expansion joint is designed: axial, lateral and angular movements. In contrast hereto expansion joints are not designed for rotational movement around the principal axis.

Axial Movement

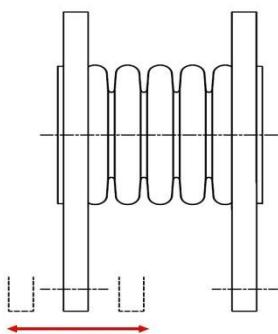

Lateral Movement

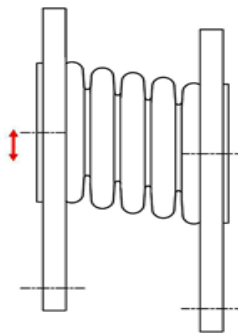

Angular Movement

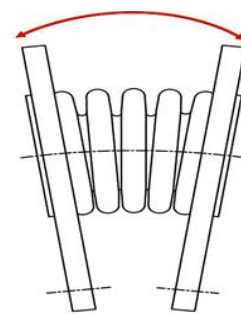

Axial movement is the most frequently required type of movement and is specified in terms of the expansion joints minimum and maximum extension and its neutral length. The neutral length represents the mid-range position. Expansion joints can be installed at lengths between the minimum and maximum length, but this of course will restrict the amount of allowable movement. CRP Expansion Joints do not require restraining to hold their neutral length and are delivered with the flanges sitting in their neutral length with the tie rods set to their maximum extension. **Lateral** movement represents travel at right angles to the principal axis. **Angular** movement is based upon travel of the flanges out of parallel.

The allowable movements are dependent upon nominal bore and number of convolutions and is provided on the following individual product nominal bore pages. It is important to understand that these movements are not independent. For combined movement calculations consider the totally allowable movement in all three directions as comprising 100%. This 100% can be apportioned across the three movement types.

FluoroFlow® PTFE-Expansion Joints

Modified Expansion Joints

The following formula can serve as a calculation basis:

$$\frac{D_x}{D_{x \max}} + \frac{D_y}{D_{y \max}} + \frac{D_a}{D_{a \max}} \leq 1$$

(D_x = axial movement; D_y = lateral movement; D_a = angular movement)

Modified Bellows

The mechanical design of flanges, tie rods and limit sleeves are to restrict movements within their safe range. However, it may be necessary to curtail movements still further, such as preventing movements in one or more planes, focus all movements in one plane or create additional movements. Special expansion joints are available for these purposes.

Pure Axial Expansion Joints (Axial Expansion Joints)

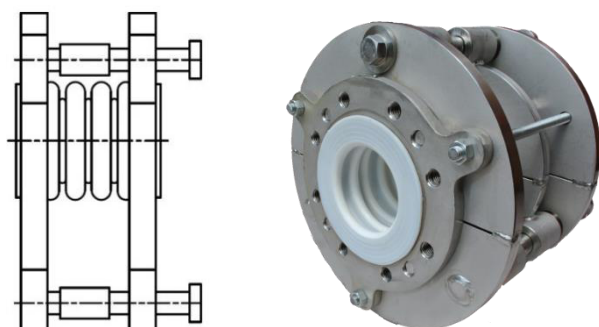

By providing an external frame with guide rods, the expansion joints can be restricted to axial movement only.

Movement	Aptitude
axial	Yes
lateral	No
angular	No

Lateral Expansion Joints

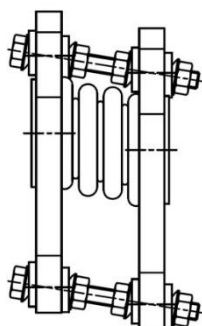

Tie rods with special spherical washers capturing the flange face allow movement in any lateral plane.

Movement	Aptitude
axial	No
lateral *)	Yes
angular	No

*) suitable for all planes without direction restriction

One Plane Angular Expansion Joints (Hinged Expansion Joints)

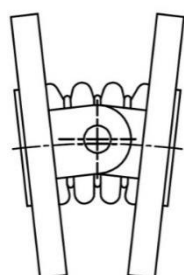

Hinged expansion joints allow angular movements only in one plane, thereby maximising the angular range.

Movement	Aptitude
axial	No
lateral	No
angular *)	Yes

*) Restriction on only one plane of movement

FluoroFlow® PTFE-Expansion Joints

Modified Expansion Joints

All Planes Angular Expansion Joints (Gimballed Expansion Joints)

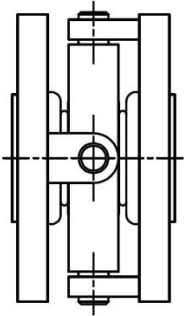

As with the hinged expansion joints they allow only angular movements, but with the addition of gimbals enables angular movement in any plane.

Movement	Aptitude
axial	No
lateral	No
angular *)	Yes

*) without restrictions for all planes of movement

Large Movement Lateral Expansion Joints (Universal Expansion Joints)

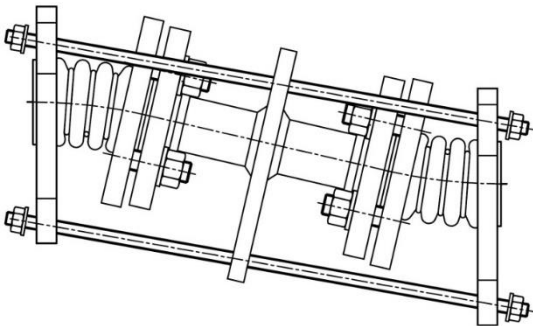

A tandem assembly of two expansion joints with an intermediate PTFE lined pipe provides wide lateral movements by effectively converting each expansion joint into angular types. Axial and angular movements are maintained further on.

Movement	Aptitude
axial	Yes
lateral	Yes
angular	Yes

Recommended bolting torques as assembly guidelines

The following information is valid for smooth bolts with lubricated threads. Following approximately 24 hours of installation the flanges should be monitored with respect to correctly applied torques. The tightening torques displayed in the table underneath shall be regarded as guidelines. They may be exceeded by up to 50% without detrimental effect.

Bolting Assembly DIN PN 10			
DN	Bolting Torque [Nm]	DN	Bolting Torque [Nm]
25	40	300	104
40	60	350	142
50	66	400	197
65	45	450	173
80	50	500	197
100	55	600	257
125	74	700	295
150	103	750	340
200	137	800	385
250	99	900	365

PTFE - Expansion Joint

Technical Data

FluoroFlow® Series FFB

1" ASME Class 150

Pos.	Component	Material	Standard
1	PTFE-Component	Paste extruded virgin PTFE or PTFE static-dissipating	ASTM D 4895
2	Flanges	Carbon Steel BS1501-161-430A Ultra-High Temperature Paint	BS1501-161-430A
3	Root Rings	Stainless Steel 320S31 (316 Ti) or Hastelloy 276 (2.4819)	SS 320S31 (316 Ti)
4	Tie Rods	Carbon Steel Grade 8.8 (Zinc plated)	EN ISO 898-1
5	Limit Sleeves	Stainless Steel ASTM A312 Gr. 304/304L	ASTM A312 Gr. 304/304L
6	Nuts	Carbon Steel Grade 8.8 (Zinc plated)	EN ISO 898-1
7	Washers	Carbon Steel Grade 8.8 (Zinc plated)	EN ISO 898-1

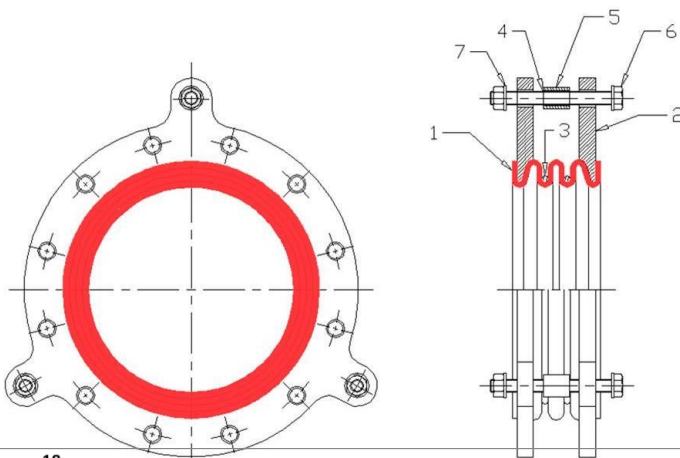

Convolutions	Vacuum Resistance bar (g)			
	20 °C	100 °C	150 °C	200 °C
FFB2 XHD	-1,0	-1,0	-1,0	-1,0
FFB3 XHD	-1,0	-1,0	-1,0	-1,0
FFB4 XHD	-1,0	-1,0	-1,0	-1,0
FFB5 XHD	-1,0	-1,0	-1,0	-1,0

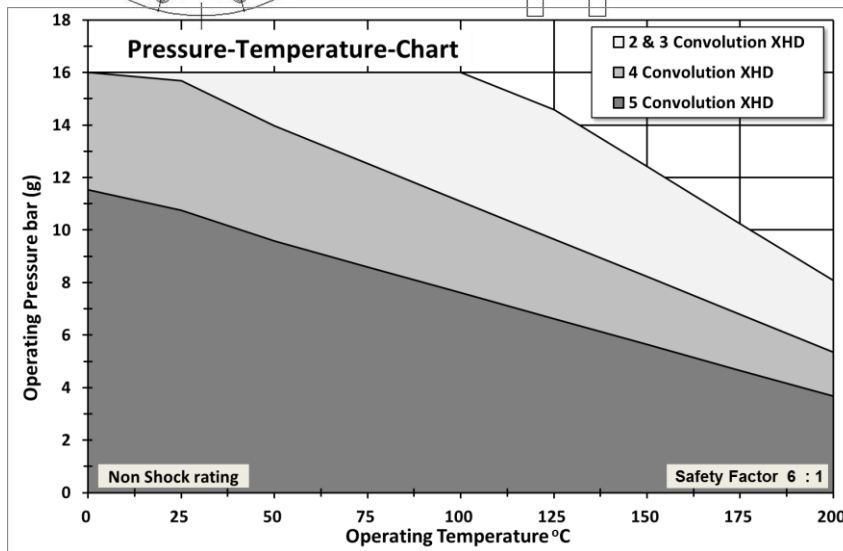

Flanges ASME Class 150	
Raised Face Ø [mm]	51
Bolt Circle Ø [mm]	79
Flange Max-Ø [mm]	167
Holes ³⁾ [No. x Thread]	4 x ½" UNC
Thickness [mm]	12
Effective Area [mm ²]	1.000

Weight [kg]	
FFB2	1,8
FFB3	2,0
FFB4	2,2
FFB5	2,4

Dimensions, Movements¹⁾ and Spring Rates²⁾

Type Convolutions	Neutral Length [mm]	axial ± [mm]	lateral ± [mm]	angular ± degrees	Spring Rate ²⁾ 20 °C ±50 %			
					Axial Comp. [N/mm]	axial Ext. [N/mm]	lateral [N/mm]	angular [Nm/°]
FFB2	43	7	4	6	242	80	69	0,5
FFB3	54	11	6	10	161	53	46	0,3
FFB4	65	15	8	13	121	40	35	0,2
FFB5	76	19	10	17	97	32	28	0,2

1) Combined movements call for considerations in common 2) Observe temperature dependence 3) Threaded flange holes are Standard

PTFE - Expansion Joint

Technical Data

FluoroFlow® Series FFB

1 1/2" ASME Class 150

Pos.	Component	Material	Standard
1	PTFE-Component	Paste extruded virgin PTFE or PTFE Static-dissipating	ASTM D 4895
2	Flanges	Carbon Steel BS1501-161-430A Ultra-High Temperature Paint	BS1501-161-430A
3	Root Rings	Stainless Steel 320S31 or Hastelloy 276 (2.4819)	SS 320S1 (316 Ti)
4	Tie Rods	Carbon Steel 8.8 (Zinc plated)	EN ISO 898-1
5	Limit Sleeves	Stainless Steel SS 304/304L	SS ASTM A312 Gr. 304/304L
6	Nuts	Carbon Steel 8.8 (Zinc plated)	EN ISO 898-1
7	Washers	Carbon Steel 8.8 (Zinc plated)	EN ISO 898-1

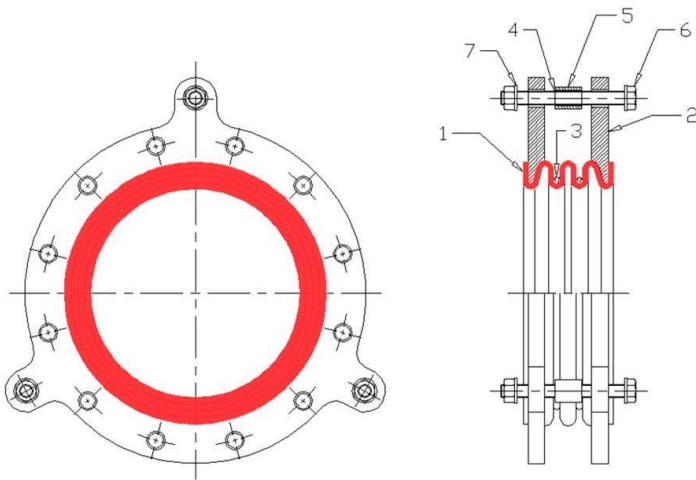

Vacuum Resistance bar (g)				
Convolutions	20 °C	100 °C	150 °C	200 °C
FFB2 XHD	-1,0	-1,0	-1,0	-1,0
FFB3 XHD	-1,0	-1,0	-1,0	-1,0
FFB4 XHD	-1,0	-1,0	-1,0	-1,0
FFB5 XHD	-1,0	-1,0	-1,0	-1,0

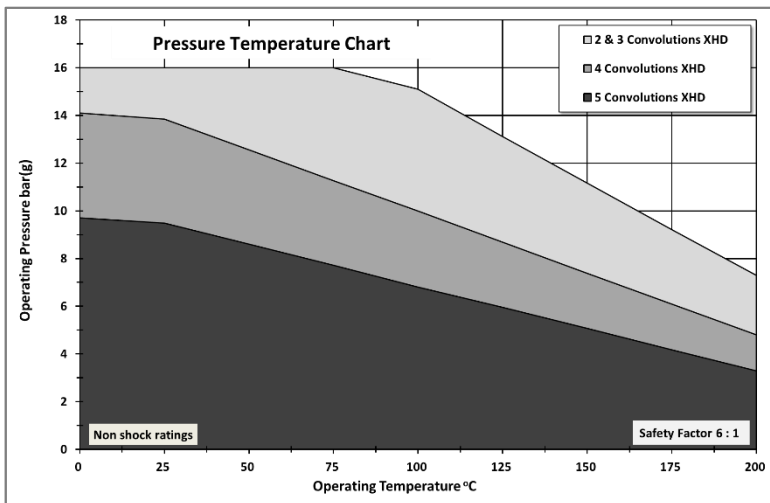

Flanges ASME Class 150	
Raised Face Ø [mm]	73
Bolt Circle Ø [mm]	98
Flange-Ø max. [mm]	204
Holes ³⁾ [No. x Thread]	4 x 1/2" UNC
Thickness [mm]	16
Effective Area [mm ²]	2.200

Weight [kg]	
FFB2	4,2
FFB3	4,5
FFB4	4,8
FFB5	5,1

Dimensions, Movements¹⁾ and Spring Rates²⁾

Type Convolutions	Neutral Length [mm]	axial ± [mm]	lateral ± [mm]	angular ± degrees	Spring Rates ²⁾ 20 °C ±50 %			
					axial Comp. [N/mm]	axial Exp. [N/mm]	lateral [N/mm]	angular [Nm/°]
FFB2	54	8	4	6	330	116	135	1,4
FFB3	69	13	6	10	220	77	90	0,9
FFB4	84	18	8	13	165	58	68	0,7
FFB5	99	23	12	17	132	46	54	0,5

1) Combined movements call for considerations in common 2) Observe temperature dependence 3) Threaded flange holes are Standard

PTFE - Expansion Joint

Technical Data

FluoroFlow® Series FFB

2" ASME Class 150

Pos.	Component	Material	Standard
1	PTFE-Component	Paste extruded virgin PTFE or PTFE Static dissipating	ASTM D 4895
2	Flanges	Carbon Steel BS1501-161-430A Ultra-High Temperature Paint	BS1501-161-430A
3	Root Rings	Stainless Steel 320S31 (316 Ti) or Hastelloy 276 (2.4819)	SS 320S31 (316 Ti)
4	Tie Rods	Carbon Steel Grade 8.8 (Zinc plated)	EN ISO 898-1
5	Limit Sleeves	Stainless Steel ASTM A312 Gr. 304/304L	SS ASTM A312 Gr. 304/304L
6	Nuts	Carbon Steel Grade 8.8 (Zinc plated)	EN ISO 898-1
7	Washers	Carbon Steel Grade 8.8 (Zinc plated)	EN ISO 898-1

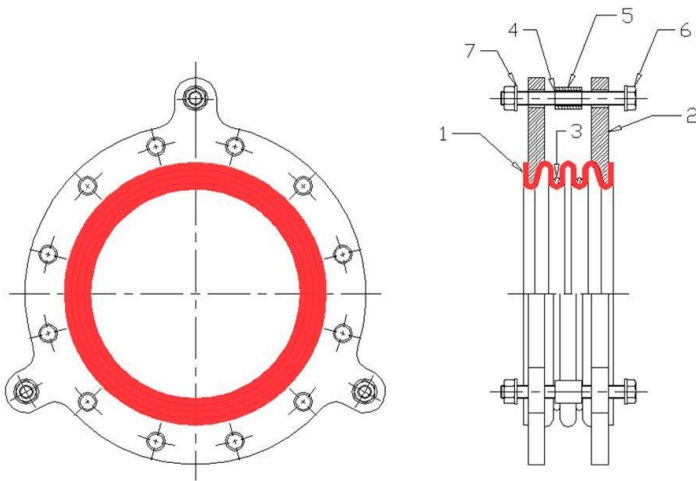

Vacuum Resistance bar (g)				
Convolutions	20 °C	100 °C	150 °C	200 °C
FFB2 XHD	-1,0	-1,0	-1,0	-1,0
FFB3 XHD	-1,0	-1,0	-1,0	-1,0
FFB4 XHD	-1,0	-1,0	-1,0	-1,0
FFB5 XHD	-1,0	-1,0	-1,0	-1,0

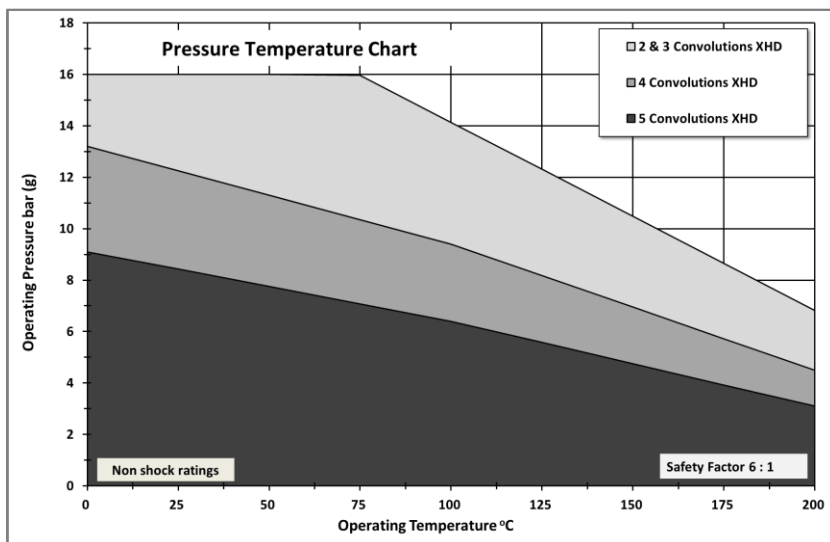

Flanges ASME Class 150	
Raised Face Ø [mm]	92
Bolt Circle Ø [mm]	121
Flange-Ø max. [mm]	220
Holes ³⁾ [No. x Thread]	4 x ½"UNC
Thickness [mm]	16
Effective Area [mm ²]	3.200

Weight [kg]	
FFB2	4,6
FFB3	4,9
FFB4	5,2
FFB5	5,5

Dimension, Movements¹⁾ and Spring Rates²⁾

Type Convolutions	Neutral Length [mm]	axial ± [mm]	lateral ± [mm]	angular ± degrees	Spring Rate ²⁾ 20 °C ±50 %			
					axial Comp. [N/mm]	axial Ext. [N/mm]	lateral [N/mm]	angular [Nm/°]
FFB2	55	11	6	7	396	135	285	2,4
FFB3	70	16	9	11	264	90	190	1,6
FFB4	85	21	12	14	198	68	143	1,2
FFB5	100	26	15	18	158	54	114	0,9

1) Combined movements call for considerations in common 2) Observe temperature dependence 3) Threaded flange holes are Standard

PTFE - Expansion Joint

Technical Data

FluoroFlow® Series FFB

2 1/2" ASME Class 150

Pos.	Components	Materials	Standard
1	PTFE-Component	Paste extruded virgin PTFE or PTFE static-dissipating	ASTM D 4895
2	Flanges	Carbon Steel BS1501-161-430A Ultra-High Temperature Paint	BS1501-161-430A
3	Root Rings	Stainless Steel 320S31 (316 Ti) or Hastelloy 276 (2.4819)	SS 320S31 (316Ti)
4	Tie Rods	Carbon Steel Grade 8.8 (Zinc plated)	EN ISO 898-1
5	Limit Sleeves	Stainless Steel ASTM A312 Gr. 304/304L	ASTM A312 Gr. 304/304L
6	Nuts	Carbon Steel Grade 8.8 (Zinc plated)	EN ISO 898-1
7	Washers	Carbon Steel Grade 8.8 (Zinc plated)	EN ISO 898-1

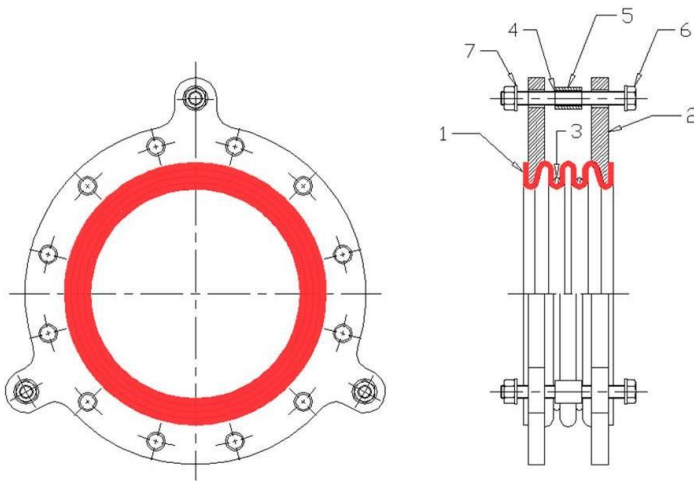

Vacuum Resistance bar (g)				
Type	20 °C	100 °C	150 °C	200 °C
FFB2 XHD	-1,0	-1,0	-1,0	-1,0
FFB3 XHD	-1,0	-1,0	-1,0	-1,0
FFB4 XHD	-1,0	-1,0	-1,0	-1,0
FFB5 XHD	-1,0	-1,0	-1,0	-1,0

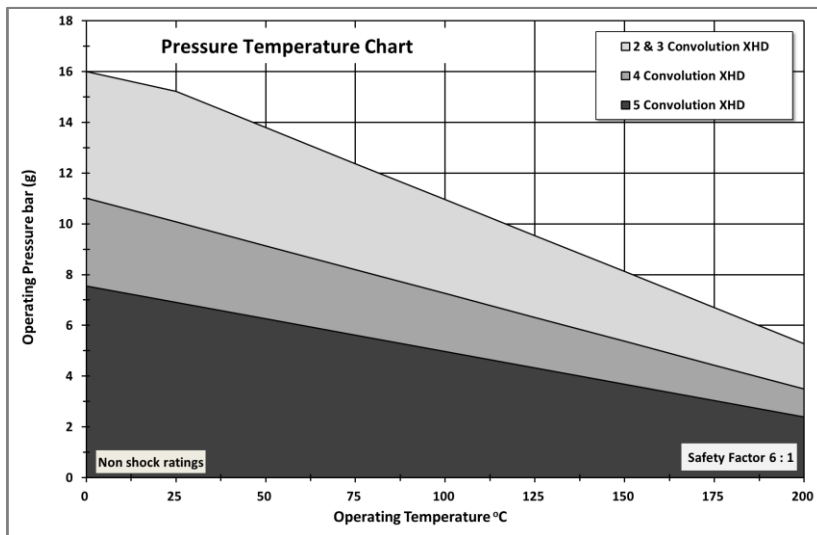

Flanges ASME Class 150	
Raised Face Ø [mm]	105
Bolt Circle Ø [mm]	140
Flange-Ø max. [mm]	240
Holes ³⁾ [No. x Thread]	4 x 5/8" UNC
Thickness [mm]	16
Effective Area [mm ²]	5.200

Weight [kg]	
FFB2	5,6
FFB3	6,0
FFB4	6,5
FFB5	7,0

Dimension, Movements¹⁾ und Spring Rates²⁾

Type Convolutions	Neutral Length [mm]	axial ± [mm]	lateral ± [mm]	angular ± degrees	Spring Rate ²⁾ 20 °C ±50 %			
					Axial Comp. [N/mm]	axial Ext. [N/mm]	lateral [N/mm]	angular [Nm/°]
FFB2	65	11	6	7	420	134	245	4,0
FFB3	85	16	9	10	280	89	163	2,7
FFB4	105	21	12	13	210	67	122	2,0
FFB5	125	26	15	16	168	53	98	1,6

1) Combined movements call for considerations in common 2) Observe temperature dependence 3) Threaded flange holes are Standard

PTFE - Expansion Joint

Technical Data

FluroFlow® Series FFB

3" ASME Class 150

Pos.	Component	Materials	Standard
1	PTFE-Component	Paste extruded virgin PTFE or PTFE static-dissipating	ASTM D 4895
2	Flanges	Carbon Steel BS1501-161-430A Ultra-High-Temperature Paint	BS1501-161-430A
3	Root Rings	Stainless Steel 320S31 (316Ti) or Hastelloy 276 (2.4819)	SS 320S31 (316Ti)
4	Tie Rods	Carbon Steel Grade 8.8 (Zinc plated)	EN ISO 898-1
5	Limit Sleeves	Stainless Steel ASTM A312 Gr. 304/304L	ASTM A312 Gr. 304/304L
6	Nuts	Carbon Steel Grade 8.8 (Zinc plated)	EN ISO 898-1
7	Washers	Carbon Steel Grade 8.8 (Zinc plated)	EN ISO 898-1

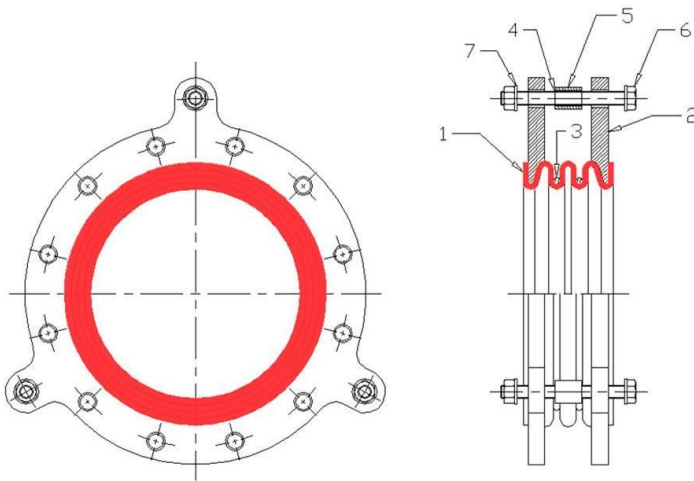

Vacuum Resistance bar (g)				
Type	20 °C	100 °C	150 °C	200 °C
FFB2 XHD	-1,0	-1,0	-1,0	-1,0
FFB3 XHD	-1,0	-1,0	-1,0	-1,0
FFB4 XHD	-1,0	-1,0	-1,0	-1,0
FFB5 XHD	-1,0	-1,0	-1,0	-1,0

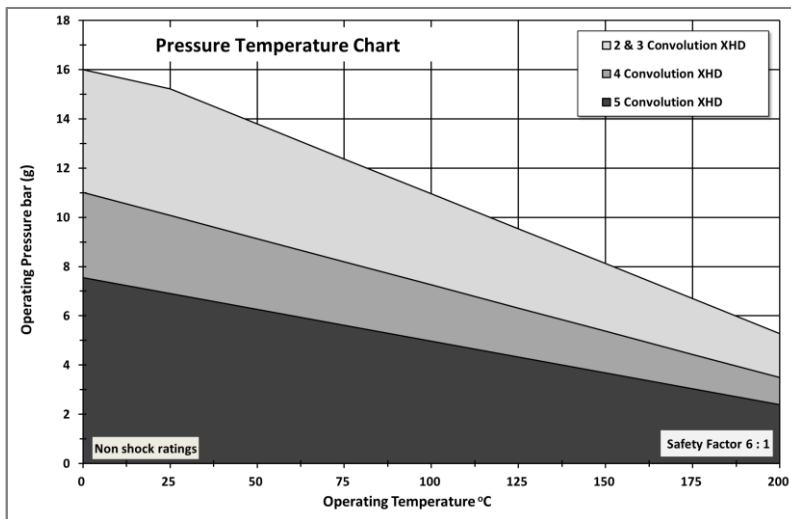

Flanges ASME Class 150	
Raised Face Ø [mm]	127
Bolt Circle Ø [mm]	152
Flange-Ø max. [mm]	260
Hole ³⁾ [No. x Thread]	4 x 5/8" UNC
Thickness [mm]	16
Effective Area [mm ²]	7.300

Weight [kg]	
FFB2	6,7
FFB3	7,3
FFB4	7,9
FFB5	8,5

Dimension, Movements¹⁾ und Spring Rate²⁾

Type Convolutions	Neutral Length [mm]	axial ± [mm]	lateral ± [mm]	angular ± degrees	Spring Rate ²⁾ 20 °C ±50 %			
					axial Comp. [N/mm]	axial Ext. [N/mm]	lateral [N/mm]	angular [Nm/°]
FFB2	65	13	7	7	465	129	275	6,0
FFB3	85	19	11	11	310	86	183	4,0
FFB4	105	24	15	14	233	65	137	3,0
FFB5	125	30	19	18	186	52	110	2,4

1) Combined movements call for considerations in common 2) Observe temperature dependence 3) Threaded flange holes are Standard

PTFE - Expansion Joint
Technical Data
FluoroFlow® Series FFB
4" ASME Class 150

Pos.	Component	Material	Standard
1	PTFE-Component	Paste extruded virgin PTFE or PTFE static-dissipating	ASTM D 4895
2	Flanges	Carbon Steel BS1501-161-430A Ultra-High Temperature Paint	BS1501-161-430A
3	Root Rings	Stainless Steel 320S31 (316Ti) or Hastelloy 276 (2.4819)	SS320S31
4	Tie Rods	Carbon Steel Grade 8.8 (Zinc plated)	EN ISO 898-1
5	Limit Sleeves	Stainless Steel ASTM A312 Gr. 304/304L	ASTM A312 Gr. 304/304L
6	Nuts	Carbon Steel Grade 8.8 (Zinc plated)	EN ISO 898-1
7	Washers	Carbon Steel Grade 8.8 (Zinc plated)	EN ISO 898-1

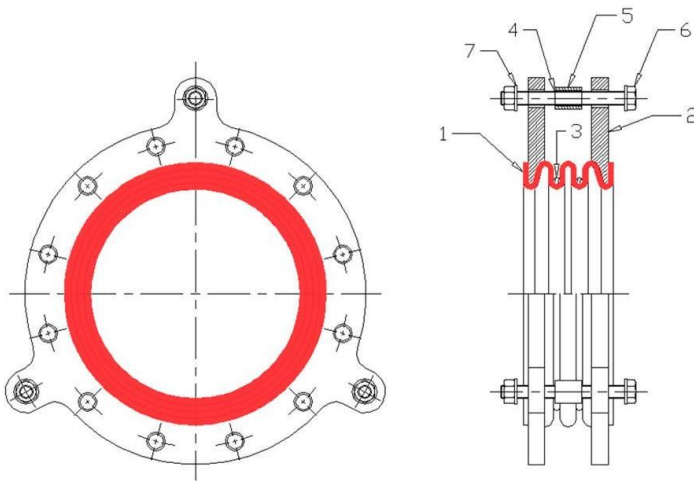

Type	Vacuum Resistance bar (g)			
	20 °C	100 °C	150 °C	200 °C
FFB2 XHD	-1,0	-1,0	-1,0	-1,0
FFB3 XHD	-1,0	-1,0	-1,0	-1,0
FFB4 XHD	-1,0	-1,0	-1,0	-1,0
FFB5 XHD	-1,0	-1,0	-1,0	-1,0

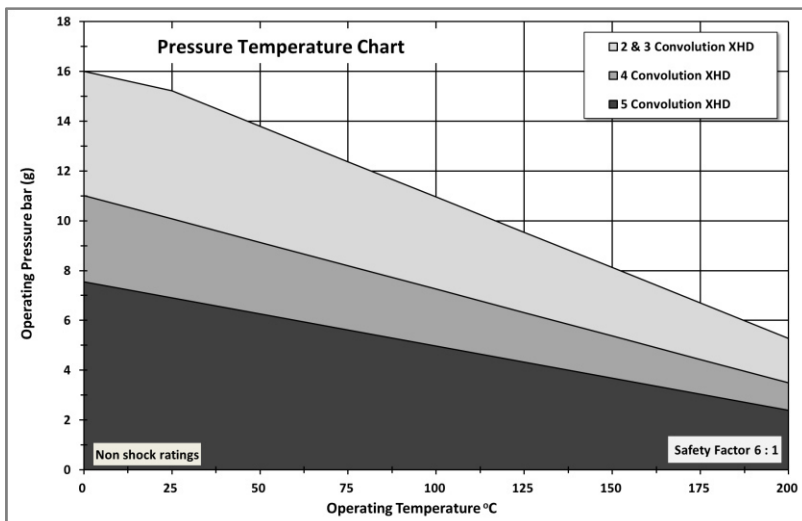

Flanges ASME Class 150	
Raised Face Ø [mm]	157
Bolt Circle Ø [mm]	191
Flange-Ø max. [mm]	308
Holes ³⁾ [No. x Thread]	8 x 5/8" UNC
Thickness [mm]	16
Effective Area [mm ²]	10.200

Weight [kg]	
FFB2	9,2
FFB3	9,7
FFB4	10,2
FFB5	10,7

Dimensions, Movements¹⁾ and Spring Rates²⁾

Type Convolutions	Neutral Length [mm]	axial ± [mm]	lateral ± [mm]	angular ± degrees	Spring Rate ²⁾ 20 °C ±50 %			
					axial Comp. [N/mm]	axial Ext. [N/mm]	lateral [N/mm]	angular [Nm/°]
FFB2	67	15	8	7	530	191	311	10,2
FFB3	91	21	12	10	353	127	207	6,8
FFB4	115	27	16	13	265	95	155	5,1
FFB5	139	33	20	17	212	76	124	4,1

1) Combined movements call for considerations in common 2) Observe temperature dependence 3) Threaded flange holes are Standard

PTFE - Expansion Joint

Technical Data

FluoroFlow® Series FFB

5" ASME Class 150

Pos.	Component	Material	Standard
1	PTFE-Component	Paste extruded virgin PTFE or PTFE static dissipating	ASTM D 4895
2	Flanges	Carbon Steel BS1501-161-430A Ultra-High Temperature Paint	BS1501-161-430A
3	Root Rings	Stainless Steel 320S31 (316Ti) or Hastelloy 276 (2.4819)	SS 320S31 (316 Ti)
4	Tie Rods	Carbon Steel Grade 8.8 (Zinc plated)	EN ISO 898-1
5	Limit Sleeves	Stainless Steel ASTM A312 Gr. 304/304L	ASTM A312 Gr. 304/304L
6	Nuts	Carbon Steel Grade 8.8 (Zinc plated)	EN ISO 898-1
7	Washers	Carbon Steel Grade 8.8 (Zinc plated)	EN ISO 898-1

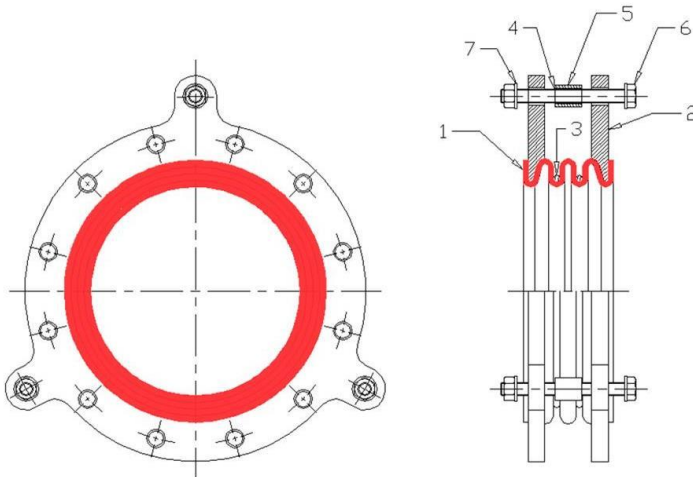

Vacuum Resistance bar (g)				
Type	20 °C	100 °C	150 °C	200 °C
FFB2 XHD	-1,0	-1,0	-1,0	-1,0
FFB3 XHD	-1,0	-1,0	-1,0	-1,0
FFB4 XHD	-1,0	-1,0	-1,0	-1,0
FFB5 XHD	-1,0	-1,0	-1,0	-1,0

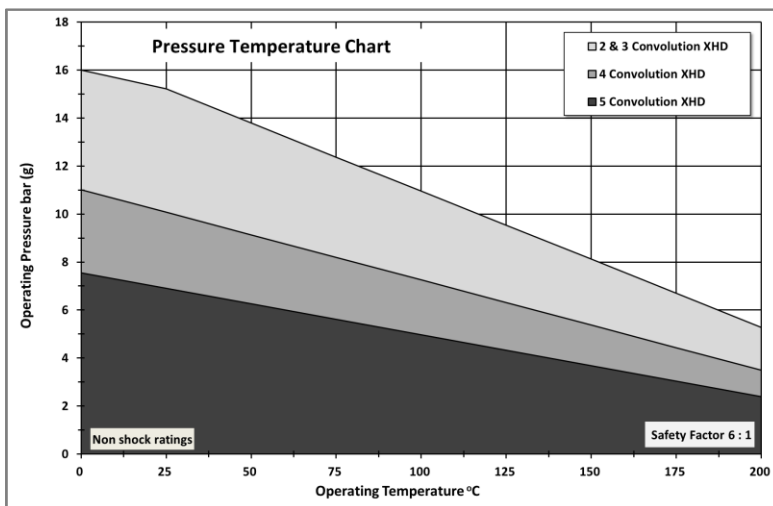

Flanges ASME Class 150	
Raised Face Ø [mm]	186
Bolt Circle Ø [mm]	216
Flange-Ø max. [mm]	333
Holes ³⁾	8 x ¾" UNC
Thickness [mm]	20
Effective Area [mm ²]	17.300

Weight [kg]	
FFB2	11,5
FFB3	12,2
FFB4	12,9
FFB5	13,6

Dimension, Movements¹⁾ and Spring Rates²⁾

Type Convolutions	Neutral Length [mm]	axial ± [mm]	lateral ± [mm]	angular ± degrees	Spring Rate *) 20 °C ±50 %			
					axial Comp. [N/mm]	axial Ext. [N/mm]	lateral [N/mm]	angular [Nm/°]
FFB2	75	15	8	6	453	225	356	16,3
FFB3	103	21	12	9	302	150	237	10,9
FFB4	131	28	16	12	227	113	178	8,1
FFB5	159	34	20	15	181	90	142	6,5

1) Combined movements call for considerations in common 2) Observe temperature dependence 3) Threaded flange holes are Standard

PTFE - Expansion Joint

Technical Data

FluoroFlow® Series FFB

6" ASME Class 150

Pos.	Component	Material	Standard
1	PTFE-Component	Paste extruded virgin PTFE or PTFE static-dissipating	ASTM D 4895
2	Flanges	Carbon Steel BS1501-161-430A Ultra-High Temperature Paint	BS1501-161-430A
3	Root Rings	Stainless Steel 320S31 (316Ti) or Hastelloy 276 (2.4819)	SS320S31 (316Ti)
4	Tie Rods	Carbon Steel Grade 8.8 (Zinc plated)	EN ISO 898-1
5	Limit Sleeves	Stainless Steel ASTM A312 Gr. 304/304L	ASTM A312 Gr. 304/304L
6	Nuts	Carbon Steel Grade 8.8 (Zinc plated)	EN ISO 898-1
7	Washers	Carbon Steel Grade 8.8 (Zinc plated)	EN ISO 898-1

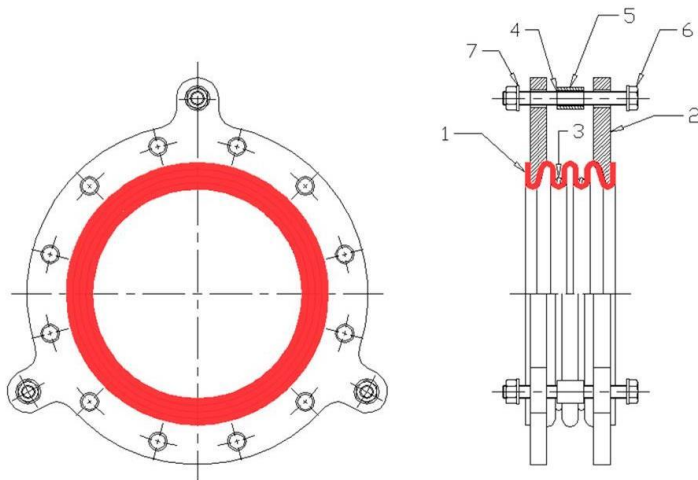

Type	Vacuum Resistance bar (g)			
	20 °C	100 °C	150 °C	200 °C
FFB2 XHD	-1,0	-1,0	-1,0	-1,0
FFB3 XHD	-1,0	-1,0	-1,0	-1,0
FFB4 XHD	-1,0	-1,0	-1,0	-1,0
FFB5 XHD	-1,0	-1,0	-1,0	-1,0

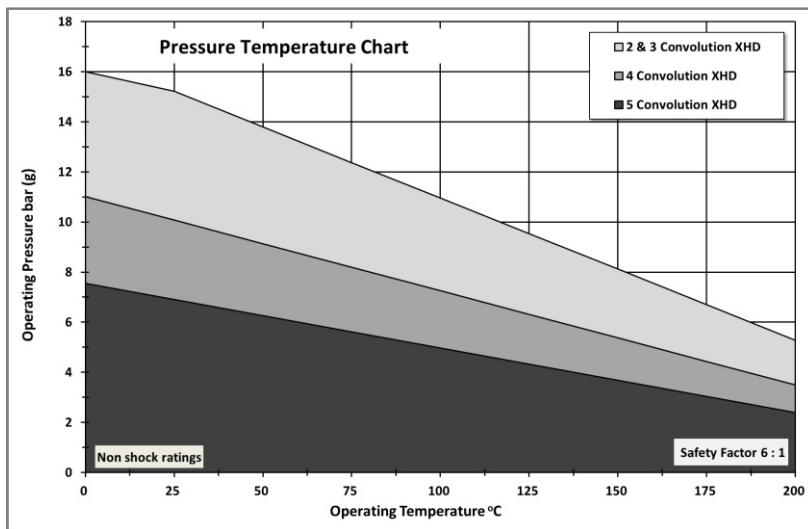

Flanges ASME Class 150	
Raised Face Ø [mm]	216
Bolt Circle Ø [mm]	241
Flange-Ø max. [mm]	378
Holes ³⁾	8 x 3/4" UNC
Thickness [mm]	20
Effective Area [mm ²]	20.900

Weight [kg]	
FFB2	14,5
FFB3	15,2
FFB4	15,9
FFB5	16,6

Dimensions, Movements¹⁾ and Spring Rates²⁾

Type Convolutions	Neutral Length [mm]	axial ± [mm]	lateral ± [mm]	angular ± degrees	Spring Rate ²⁾ 20 °C ±50 %			
					axial Comp. [N/mm]	axial Ext. [N/mm]	lateral [N/mm]	angular [Nm/°]
FFB2	75	16	8	6	900	300	600	34,8
FFB3	103	22	12	8	600	200	400	23,2
FFB4	131	29	17	11	450	150	300	17,4
FFB5	159	35	21	14	360	120	240	13,9

1) Combined movements call for considerations in common 2) Observe temperature dependence 3) Threaded flange holes are Standard

PTFE - Expansion Joint

Technical Data

FluoroFlow® Series FFB

8" ASME Class 150

Pos.	Component	Material	Standard
1	PTFE-Component	Paste extruded virgin PTFE or PTFE static-dissipating	ASTM D 4895
2	Flange	Carbon Steel BS1501-161-430A Ultra-High Temperature Paint	BS1501-161-430A
3	Root Rings	Stainless Steel 320S31 (316Ti) or Hastelloy 276 (2.4819)	SS 320S31 (316Ti)
4	Tie Rods	Carbon Steel Grade 8.8 (Zinc plated)	EN ISO 898-1
5	Limit Sleeves	Stainless Steel ASTM A312 Gr. 304/304L	ASTM A312 Gr. 304/304L
6	Nuts	Carbon Steel Grade 8.8 (Zinc plated)	EN ISO 898-1
7	Washers	Carbon Steel Grade 8.8 (Zinc plated)	EN ISO 898-1

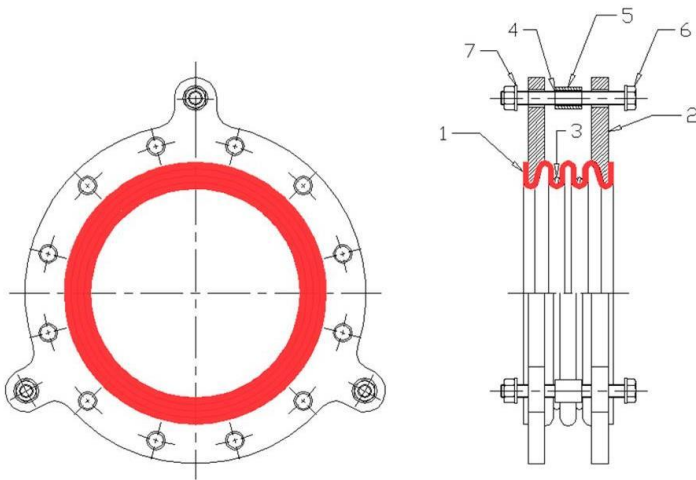

Vacuum Resistance bar (g)				
Type	20 °C	100 °C	150 °C	200 °C
FFB2 XHD	-1,0	-1,0	-1,0	-1,0
FFB3 XHD	-1,0	-1,0	-1,0	-1,0
FFB4 XHD ⁴⁾	-1,0	-1,0	-1,0	-0,8
FFB5 XHD	-1,0	-1,0	-1,0	-0,8

4) Full vacuum with inner support rings possible

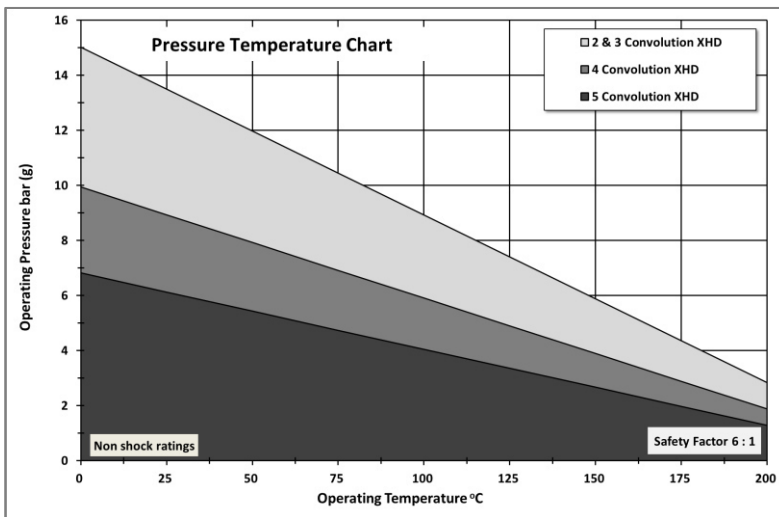

Flanges ASME Class 150	
Raised Face Ø [mm]	270
Bolt Circle Ø [mm]	298
Flange-Ø max. [mm]	440
Holes ³⁾	8 x 3/4" UNC
Thickness [mm]	20
Effective Area [mm ²]	35.300

Weight [kg]	
FFB2	19,5
FFB3	20,3
FFB4	21,1
FFB5	21,9

Dimensions, Movements¹⁾ and Spring Rates²⁾

Type Convolutions	Neutral Length [mm]	axial ± [mm]	lateral ± [mm]	angular ± degrees	Spring Rates ²⁾ 20 °C ±30 %			
					axial Comp. [N/mm]	axial Ext. [N/mm]	lateral [N/mm]	Angular [Nm/°]
FFB2	75	17	8	5	1089	360	675	71,0
FFB3	103	24	12	8	726	240	450	47,3
FFB4	131	31	17	10	545	180	338	35,5
FFB5	159	38	21	12	436	144	270	28,4

1) Combined movements call for considerations in common 2) Observe temperature dependence 3) Threaded flange holes are Standard

PTFE - Expansion Joint

Technical Data

FluoroFlow® Series FFB

10" ASME Class 150

Pos.	Component	Material	Standard
1	PTFE-Component	Multi-ply virgin PTFE or PTFE static-dissipating	ASTM D 4894 Type IV
2	Flanges	Carbon Steel BS1501-161-430A Ultra-High Temperature Paint	BS1501-161-430A
3	Root Rings	Stainless Steel 320S31 (316Ti) or Hastelloy 276 (2.4819)	SS 320S31 (316Ti)
4	Tie Rods	Carbon Steel Grade 8.8 (Zinc plated)	EN ISO 898-1
5	Limit Sleeves	Stainless Steel ASTM A312 Gr. 304/304L	ASTM A312 Gr. 304/304L
6	Nuts	Carbon Steel Grade 8.8 (Zinc plated)	EN ISO 898-1
7	Washers	Carbon Steel Grade 8.8 (Zinc plated)	EN ISO 898-1

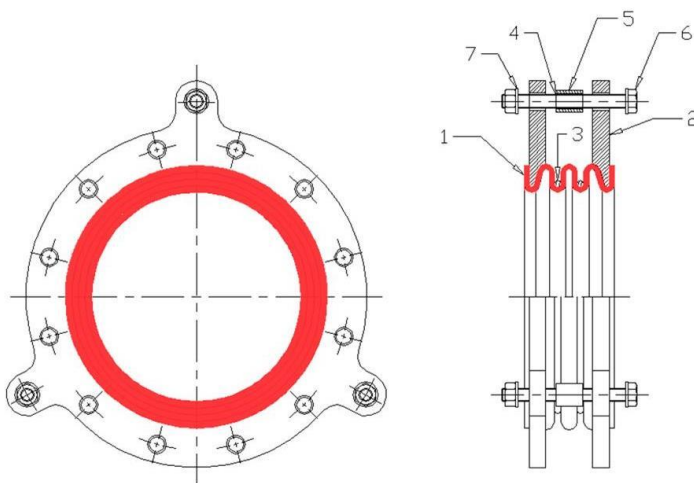

Type	Vacuum Resistance bar (g)			
	20 °C	100 °C	150 °C	200 °C
FFB 2 XHD	-1,0	-1,0	-1,0	-0,9
FFB 3 XHD	-1,0	-1,0	-0,9	-0,8
FFB 4 XHD	-1,0	-0,8	-0,7	-0,6
FFB 5 XHD	-1,0	-0,7	-0,6	-0,6

Full vacuum with inner support rings upon request

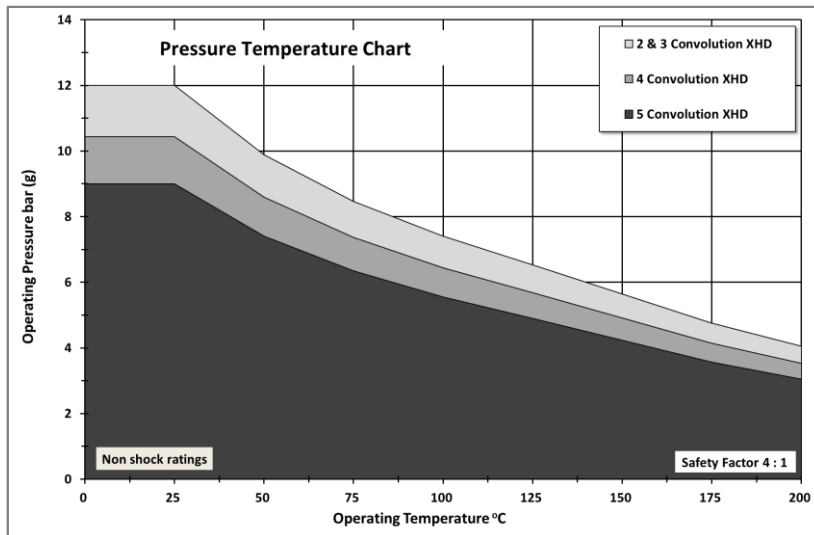

Flanges ASME Class 150	
Raised Face Ø [mm]	324
Bolt Circle Ø [mm]	362
Flange-Ø max. [mm]	514
Holes ³⁾	12 x 7/8" UNC
Thickness [mm]	20
Effective Area [mm ²]	56.600

Weight [kg]	
FFB2	24,2
FFB3	25,4
FFB4	26,2
FFB5	27,0

Dimensions, Movements¹⁾ and Spring Rates²⁾

Type Convolutions	Neutral Length [mm]	axial ± [mm]	lateral ± [mm]	angular ± degrees	Spring Rate ²⁾ 20°C ± 50 %			
					axial Comp. [N/mm]	axial Ext. [N/mm]	lateral [N/mm]	angular [Nm/°]
FFB2	78	19	8	5	2250	563	488	221
FFB3	107	26	12	7	1500	375	325	147
FFB4	135	32	17	9	1125	281	244	110
FFB5	164	39	21	11	900	225	195	88

1) Combined movements call for considerations in common 2) Observe temperature dependence 3) Threaded flange holes are Standard

PTFE - Expansion Joint

Technical Data

FluoroFlow® Series FFB

12" ASME Class 150

Pos.	Component	Material	Standard
1	PTFE-Component	Multi-ply virgin PTFE or PTFE static-dissipative	ASTM D 4894 Type IV
2	Flanges	Carbon Steel BS1501-161-430A Ultra-High Temperature Paint	BS1501-161-430A
3	Root Rings	Stainless Steel 320S31 (316Ti) or Hastelloy 276 (2.4819)	SS 320S31 (316Ti)
4	Tie Rods	Carbon Steel Grade 8.8 (Zinc plated)	EN ISO 898-1
5	Limit Sleeves	Stainless Steel ASTM A312 Gr. 304/304L	ASTM A312 Gr. 304/304L
6	Nuts	Carbon Steel Grade 8.8 (Zinc plated)	EN ISO 898-1
7	Washers	Carbon Steel Grade 8.8 (Zinc plated)	EN ISO 898-1

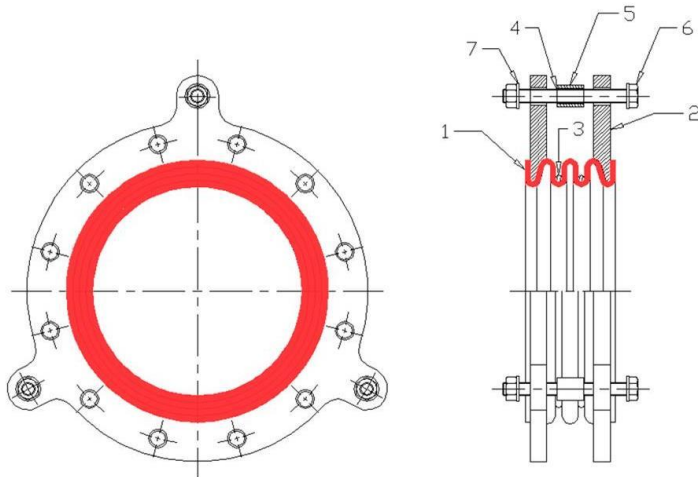

Vacuum Resistance bar (g)			
Typ	20 °C	100 °C	150 °C
FFB2 HD	-1,0	-1,0	0,0
FFB3 HD	-1,0	-1,0	0,0
FFB2 XHD	-1,0	-1,0	-1,0
FFB3 XHD ⁴⁾	-1,0	-1,0	-0,9

⁴⁾ Full vacuum with inner support rings upon request

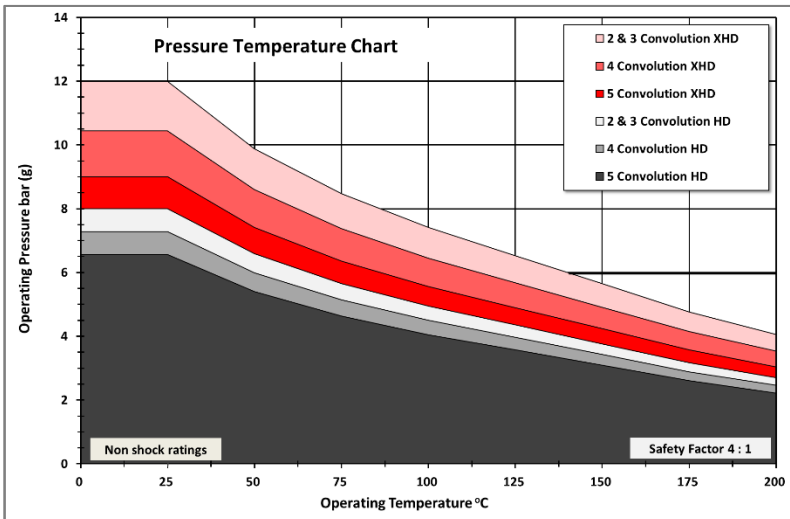

Flanges ASME Class 150	
Raised Face Ø [mm]	381
Bolt Circle Ø [mm]	432
Flanges-Ø max. [mm]	590
Holes ³⁾	12 x 7/8" UNC
Thickness [mm]	20
Effective Area [mm ²]	77.700

Weight [kg]	
FFB2	35
FFB3	36
FFB4	37
FFB5	38

Dimensions, Movements¹⁾ and Spring Rates²⁾

Type Convolutions	Neutral Length [mm]	axial ± [mm]	lateral ± [mm]	angular ± degrees	Spring Rates ²⁾ 20 °C ±30 %			
					axial Comp. [N/mm]	axial Ext. [N/mm]	lateral [N/mm]	angular [Nm/°]
FFB2	95	19	9	4	2075	690	636	298
FFB3	132	26	13	6	1383	460	424	199
FFB4	169	33	18	8	1037	345	318	149
FFB5	206	40	22	9	830	276	254	119

1) Combined movements call for considerations in common 2) Observe temperature dependence 3) Threaded flange holes are Standard

PTFE - Expansion Joint

Technical Data

FluoroFlow® Series FFB

14" ASME Class 150

Pos.	Component	Material	Standard
1	PTFE-Component	Multi-ply virgin PTFE or PTFE static-dissipating	ASTM D 4894 Type IV
2	Flanges	Carbon Steel BS1501-161-430A Ultra-High Temperature Paint	BS1501-161-430A
3	Root Rings	Stainless Steel 320S31(316Ti) or Hastelloy 276 (2.4819)	SS320S31 (316Ti)
4	Tie Rods	Carbon Steel Grade 8.8 (Zinc plated)	EN ISO 898-1
5	Limit Sleeves	Stainless Steel ASTM A312 Gr. 304/304L	ASTM 312 Gr. 304/304L
6	Nuts	Carbon Steel Grade 8.8 (Zinc plated)	EN ISO 898-1
7	Washers	Carbon Steel Grade 8.8 (Zinc plated)	EN ISO 898-1

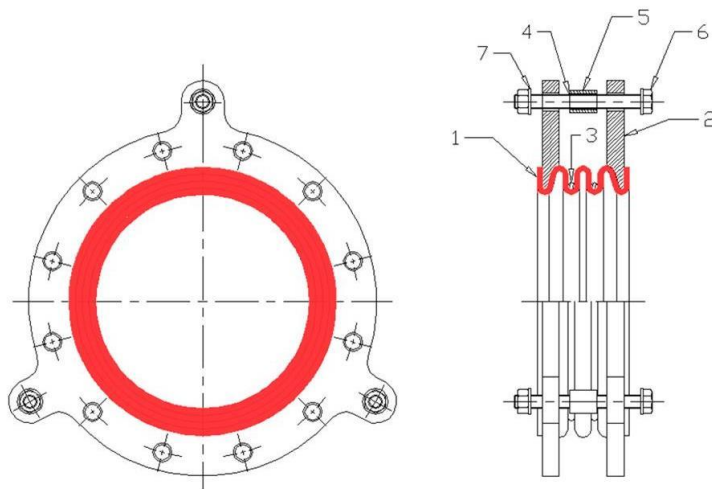

Vacuum Resistance bar (g)
Please consult ⁴⁾

⁴⁾ Suitable for vacuum with inner support rings

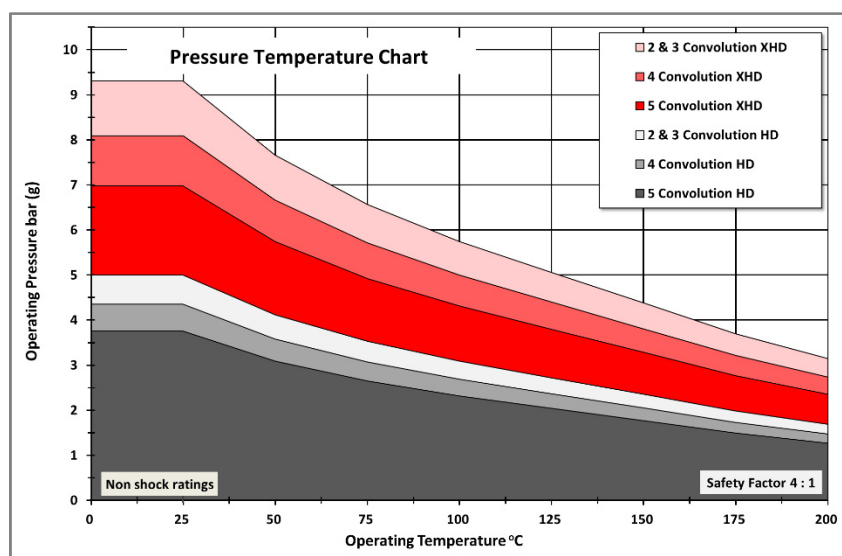

Flange ASME Class 150	
Raised Face Ø [mm]	413
Bolt Circle Ø [mm]	476
Flange-Ø max. [mm]	640
Holes ³⁾	12 x 1" UNC
Thickness [mm]	22
Effective Area [m ²]	0,1074

Weight [kg]	
FFB2	65
FFB3	66
FFB4	67
FFB5	68

Dimensions, Movements¹⁾ and Spring Rates²⁾

Type Convolution	Neutral Length [mm]	axial ± [mm]	lateral ± [mm]	angular ± degrees	Spring Rates ²⁾ 20 °C ±30 %			
					axial Comp. [N/mm]	axial Ext. [N/mm]	lateral [N/mm]	angular [Nm/°]
FFB2	98	20	8	3	1554	1020	1008	384
FFB3	137	27	12	5	1036	680	672	256
FFB4	176	34	17	6	777	510	504	192
FFB5	215	41	21	7	622	408	403	153

1) Combined movements call for considerations in common 2) Observe temperature dependence 3) Threaded flange holes are Standard

PTFE - Expansion Joint

Technical Data

FluoroFlow® Series FFB

16" ASME Class 150

Pos.	Component	Material	Standard
1	PTFE-Component	Multi-ply virgin PTFE or PTFE static-dissipating	ASTM D 4894 Type IV
2	Flanges	Carbon Steel BS1501-161-430A Ultra-High Temperature Paint	BS1501-161-430A
3	Root Rings	Stainless Steel 320S31 (316Ti) or Hastelloy 276 (2.4819)	SS320S31 (316Ti)
4	Tie Rods	Carbon Steel Grade 8.8 (Zinc plated)	EN ISO 898-1
5	Limit Sleeves	Stainless Steel ASTM A312 Gr. 304/304L	ASTM A312 Gr. 304/304L
6	Nuts	Carbon Steel Grade 8.8 (Zinc plated)	EN ISO 898-1
7	Washers	Carbon Steel Grade 8.8 (Zinc plated)	EN ISO 898-1

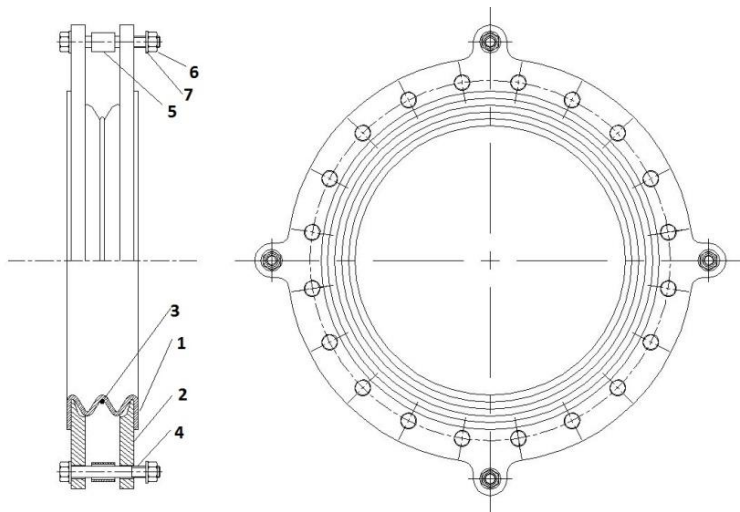

Vacuum Resistance bar (g)

Please consult ⁴⁾

⁴⁾ Suitable for vacuum with inner support rings

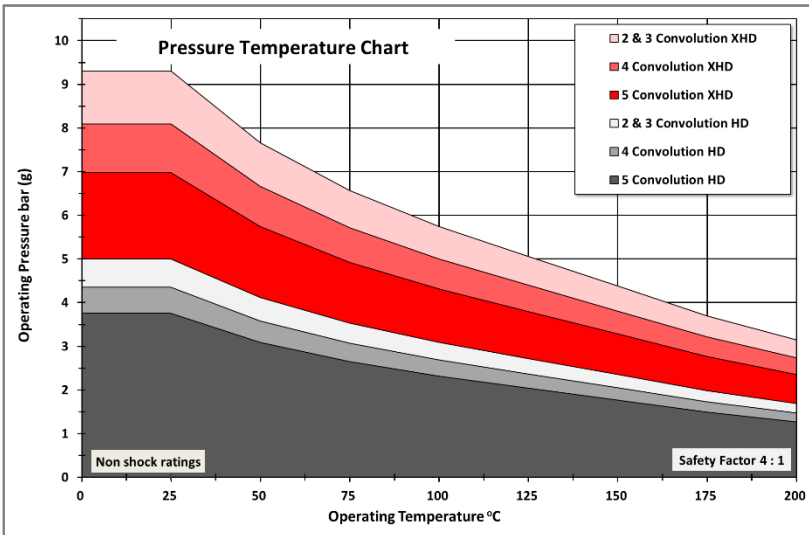

Flanges ASME Class 150

Raised Face Ø [mm]	470
Bolt Circle Ø [mm]	540
Flange-Ø max. [mm]	700
Holes ³⁾	16 x 1" UNC
Thickness [mm]	20
Effective Area [m ²]	0,1411

Weight [kg]

FFB2	79
FFB3	80
FFB4	81
FFB5	83

Dimensions, Movements¹⁾ and Spring Rates²⁾

Type Convolutions	Neutral Length [mm]	axial ± [mm]	lateral ± [mm]	angular ± degrees	Spring Rates ²⁾ 20 °C ±30 %			
					axial Comp. [N/mm]	axial Ext. [N/mm]	lateral [N/mm]	angular [Nm/°]
FFB2	117	20	10	3	1455	870	1380	57
FFB3	162	28	15	4	970	580	920	38
FFB4	207	36	20	6	728	435	690	29
FFB5	252	44	25	7	582	348	552	23

1) Combined movements call for considerations in common 2) Observe temperature dependence 3) Threaded flange holes are Standard

PTFE - Expansion Joint

Technical Data

FluoroFlow® Series FFB

18" ASME Class 150

Pos.	Component	Material	Standard
1	PTFE-Component	Multi-ply virgin PTFE or PTFE static-dissipating	ASTM D 4894 Type IV
2	Flanges	Carbon Steel BS1501-161-430A Ultra-High Temperature Paint	BS1501-161-430A
3	Root Rings	Stainless Steel 320S31 (316Ti) or Hastelloy 276 (2.4819)	SS320S31 (316Ti)
4	Tie Rods	Carbon Steel Grade 8.8 (Zinc plated)	EN ISO 898-1
5	Limit Sleeves	Stainless Steel ASTM A312 Gr. 304/304L	ASTM A312 Gr. 304/304L
6	Nuts	Carbon Steel Grade 8.8 (Zinc plated)	EN ISO 898-1
7	Washers	Carbon Steel Grade 8.8 (Zinc plated)	EN ISO 898-1

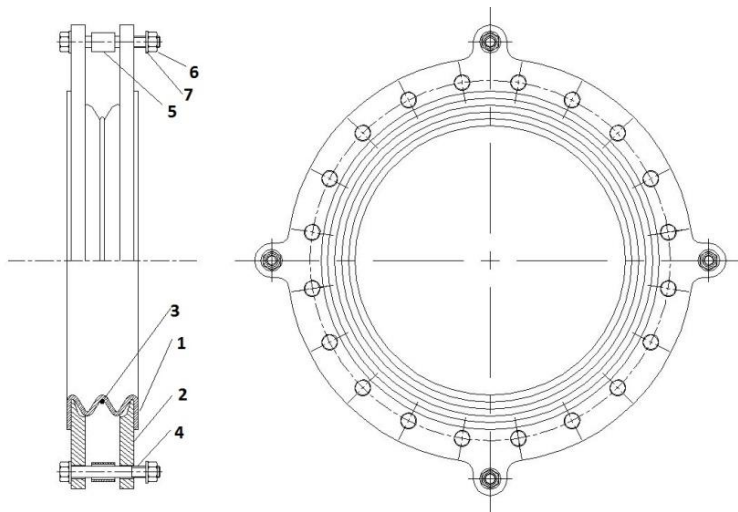

Vacuum Resistance bar (g)

Please consult ⁴⁾

⁴⁾ Suitable for vacuum with inner support rings

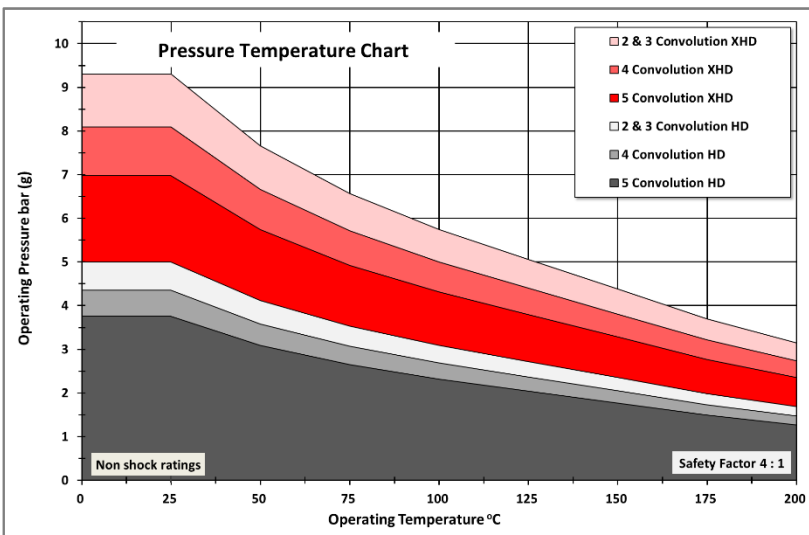

Flanges ASME Class 150

Raised Face Ø [mm]	533
Bolt Circle Ø [mm]	578
Flange-Ø max. [mm]	740
Holes ³⁾	16 x 1 1/8" UNC
Thickness [mm]	22
Effective Area [m ²]	0,180

Weight [kg]

FFB2	82
FFB3	84
FFB4	85
FFB5	86

Dimensions, Movements¹⁾ and Spring Rates²⁾

Type Convolutions	Neutral Length [mm]	axial ± [mm]	lateral ± [mm]	angular ± degrees	Spring Rates ²⁾ 20 °C ±30 %			
					axial Comp. [N/mm]	axial Ext. [N/mm]	lateral [N/mm]	angular [Nm/°]
FFB2	118	20	11	3	2325	1290	1553	66
FFB3	163	28	15	4	1550	860	1035	44
FFB4	208	36	20	5	1163	645	776	33
FFB5	253	44	24	7	930	516	621	26

1) Combined movements call for considerations in common 2) Observe temperature dependence 3) Threaded flange holes are Standard

PTFE - Expansion Joint

Technical Data

FluoroFlow® Series FFB

20" ASME Class 150

Pos.	Component	Material	Standard
1	PTFE-Component	Multi-ply virgin PTFE or PTFE static-dissipating	ASTM D 4894 Type IV
2	Flanges	Carbon Steel BS1501-161-430A Ultra-High Temperature Paint	BS1501-161-430A
3	Root Rings	Stainless Steel 320S31 (316Ti) or Hastelloy 276 (2.4819)	SS320S31 (316Ti)
4	Tie Rods	Carbon Steel Grade 8.8 (Zinc plated)	EN ISO 898-1
5	Limit Sleeves	Stainless Steel ASTM A312 Gr. 304/304L	ASTM A312 Gr. 304/304L
6	Nuts	Carbon Steel Grade 8.8 (Zinc plated)	EN ISO 898-1
7	Washers	Carbon Steel Grade 8.8 (Zinc plated)	EN ISO 898-1

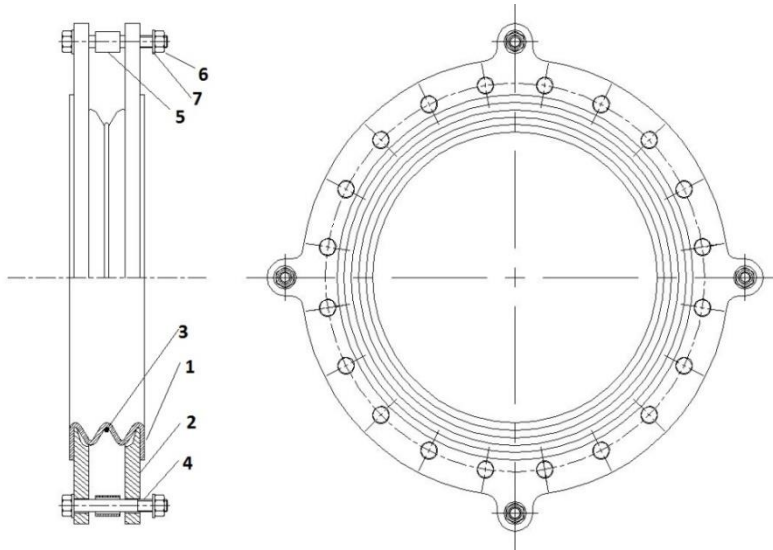

Vacuum Resistance bar (g)
Please consult ⁴⁾

⁴⁾ Suitable for vacuum with inner support rings

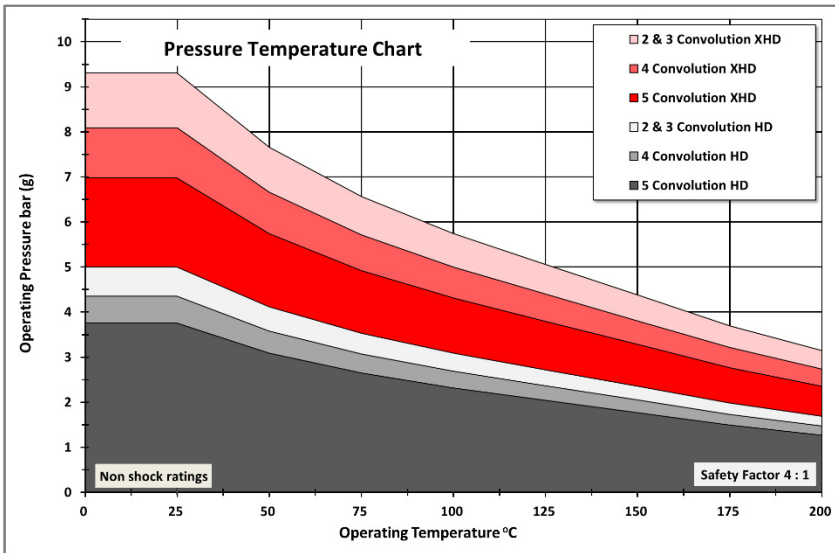

Flanges ASME Class 150	
Raised Face Ø [mm]	584
Bolt Circle Ø [mm]	635
Flange-Ø max. [mm]	830
Holes ³⁾	20 x 1 1/8" UNC
Thickness [mm]	25
Effective Area [m ²]	0,2164

Weight [kg]	
FFB2	104
FFB3	106
FFB4	108
FFB5	109

Dimensions, Movements¹⁾ and Spring Rates²⁾

Type Convolutions	Neutral Length [mm]	axial ± [mm]	lateral ± [mm]	angular ± degrees	Spring Rates ²⁾ 20 °C ±30 %			
					axial Comp. [N/mm]	axial Ext. [N/mm]	lateral [N/mm]	angular [Nm/°]
FFB2	125	20	11	2	2.865	1.605	1.725	74
FFB3	170	28	15	4	1.910	1.070	1.150	50
FFB4	215	36	20	5	1.433	803	863	37
FFB5	260	44	24	6	1.146	642	690	30

1) Combined movements call for considerations in common 2) Observe temperature dependence 3) Threaded flange holes are Standard

PTFE - Expansion Joint

Technical Data

FluoroFlow® Series FFB

24" ASME Class 150

Pos.	Component	Material	Standard
1	PTFE-Component	Multi-ply virgin PTFE or PTFE static-dissipating	ASTM D 4894 Type IV
2	Flanges	Carbon Steel BS1501-161-430A Ultra-High Temperature Paint	BS1501-161-430A
3	Root Rings	Stainless Steel 320S31 (316Ti) or Hastelloy 276 (2.4819)	SS 320S31 (316Ti)
4	Tie Rods	Carbon Steel Grade 8.8 (Zinc plated)	EN ISO 898-1
5	Limit Sleeves	Stainless Steel ASTM A312 Gr. 304/304L	ASTM A312 Gr. 304/304L
6	Nuts	Carbon Steel Grade 8.8 (Zinc plated)	EN ISO 898-1
7	Washers	Carbon Steel Grade 8.8 (Zinc plated)	EN ISO 898-1

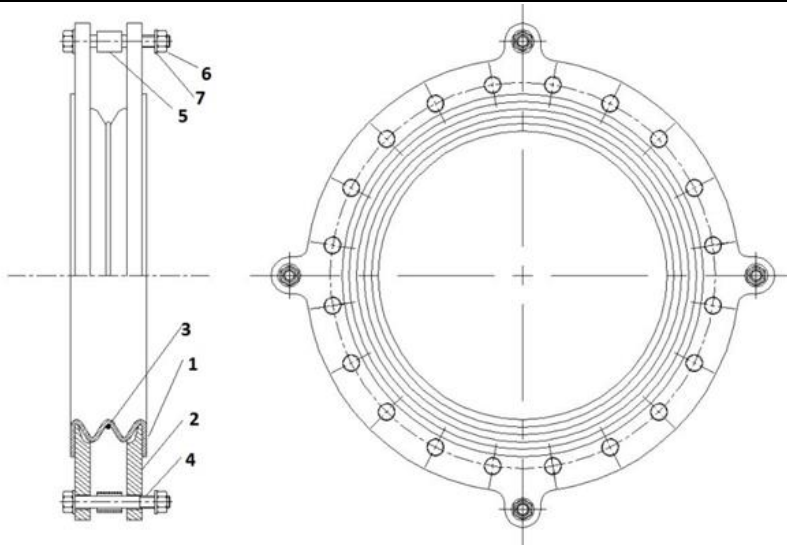

Vacuum Resistance bar (g)
Please consult ⁴⁾

⁴⁾ Suitable for vacuum with inner support rings

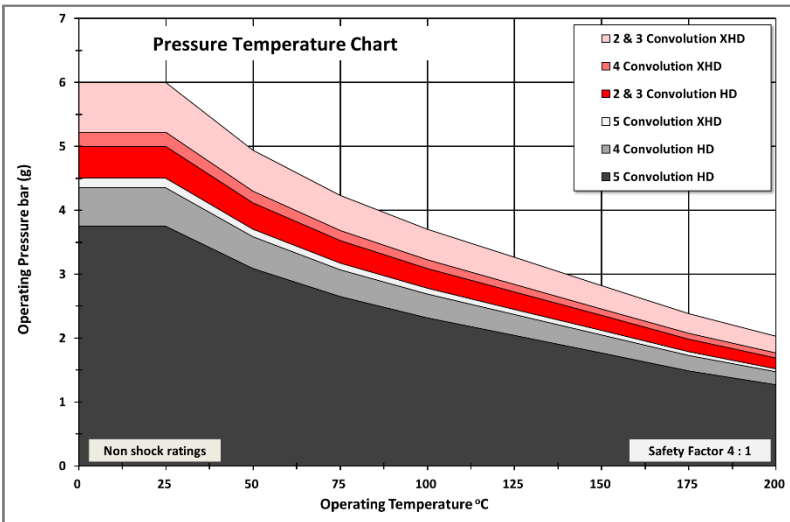

Flanges ASME Class 150	
Raised Face Ø [mm]	692
Bolt Circle Ø [mm]	749
Flange-Ø max. [mm]	935
Holes ³⁾	20 x 1 ¼" UNC
Thickness [mm]	25
Effective Area [m ²]	0,3077

Weight [kg]	
FFB2	140
FFB3	142
FFB4	145
FFB5	147

Dimensions, Movements¹⁾ and Spring Rates²⁾

Type Convolutions	Neutral Length [mm]	axial ± [mm]	lateral ± [mm]	angular ± degrees	Spring Rates ²⁾ 20 °C ±30 %			
					axial Comp. [N/mm]	axial Ext. [N/mm]	lateral [N/mm]	angular [Nm/°]
FFB2	130	20	11	2	2.865	1.605	1.725	74
FFB3	175	28	15	3	1.910	1.070	1.150	50
FFB4	220	37	20	4	1.433	803	863	37
FFB5	265	45	24	5	1.146	642	690	30

1) Combined movements call for considerations in common 2) Observe temperature dependence 3) Threaded flange holes are Standard

PTFE - Expansion Joint

Technical Data

FluoroFlow® Series FFB

28" ASME Class 150

Pos.	Component	Material	Standard
1	PTFE-Component	Multi-ply virgin PTFE or PTFE static-dissipating	ASTM D 4894 Type IV
2	Flanges	Carbon Steel BS1501-161-430A Ultra-High Temperature Paint	BS1501-161-430A
3	Root Rings	Stainless Steel 320S31 (316Ti) Hastelloy 276 (2.4819)	SS320S31 (316Ti)
4	Tie Rods	Carbon Steel Grade 8.8 (Zinc plated)	EN ISO 898-1
5	Limit Sleeves	Stainless Steel ASTM A312 Gr. 304/304A	ASTM A312 Gr. 304/304L
6	Nuts	Carbon Steel Grade 8.8 (Zinc plated)	EN ISO 898-1
7	Washers	Carbon Steel Grade 8.8 (Zinc plated)	EN ISO 898-1

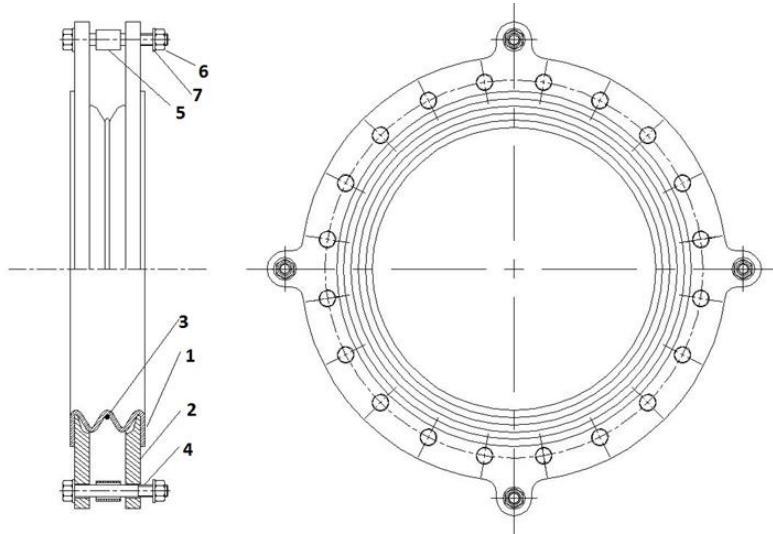

Vacuum Resistance bar (g)

Please consult ⁴⁾

⁴⁾ Suitable for vacuum with inner support rings

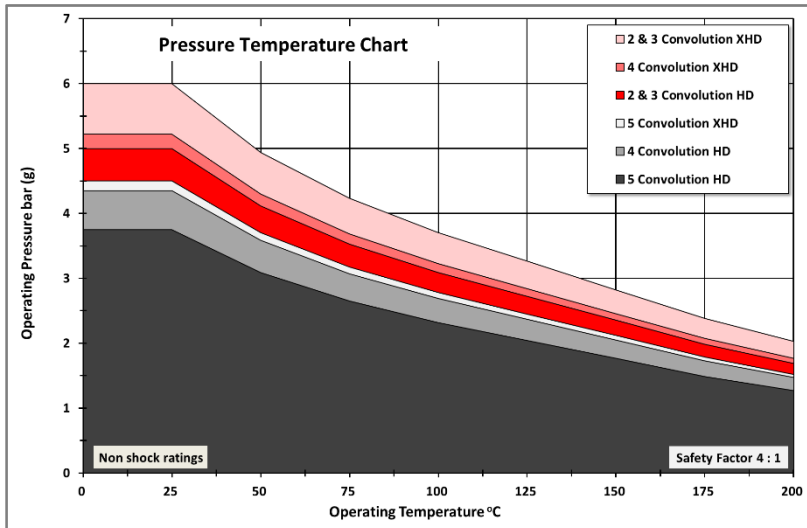

Flanges ASME Class 150 Series A

Raised Face Ø [mm]	800
Bolt Circle Ø [mm]	864
Flange-Ø max. [mm]	1060
Holes ³⁾	28 x 1 1/4" UNC
Thickness [mm]	27
Effective Area [m ²]	0,4228

Weight [kg]

FFB2	154
FFB3	157
FFB3	160
FFB4	163

Dimensions, Movements¹⁾ and Spring Rates²⁾

Type Convolution	Neutral Length [mm]	axial ± [mm]	lateral ± [mm]	angular ± degrees	Spring Rates ²⁾ 20 °C ±30 %			
					axial Comp. [N/mm]	axial Ext. [N/mm]	lateral [N/mm]	angular [Nm/°]
FFB2	146	25	12	2	3.120	2.415	5.745	135
FFB3	207	32	16	3	2.080	1.610	3.830	90
FFB4	268	39	20	3	1.561	1.208	2.837	67
FFB5	329	46	24	4	1.248	966	2.298	54

1) Combined movements call for considerations in common 2) Observe temperature dependence 3) Threaded flange holes are Standard

PTFE - Expansion Joint

Technical Data

FluoroFlow® Series FFB

30" ASME Class 150

Pos.	Component	Material	Standard
1	PTFE-Component	Multi-ply virgin PTFE or PTFE static-dissipating	ASTM D 4894 Type IV
2	Flanges	Carbon Steel BS1501-161-430A Ultra-High Temperature Paint	BS1501-161-430A
3	Root Rings	Stainless Steel 320S31 (316Ti) Hastelloy 276 (2.4819)	SS320S31 (316Ti)
4	Tie Rods	Carbon Steel Grade 8.8 (Zinc plated)	EN ISO 898-1
5	Limit Sleeves	Stainless Steel ASTM A312 Gr. 304/304A	ASTM A312 Gr. 304/304L
6	Nuts	Carbon Steel Grade 8.8 (Zinc plated)	EN ISO 898-1
7	Washers	Carbon Steel Grade 8.8 (Zinc plated)	EN ISO 898-1

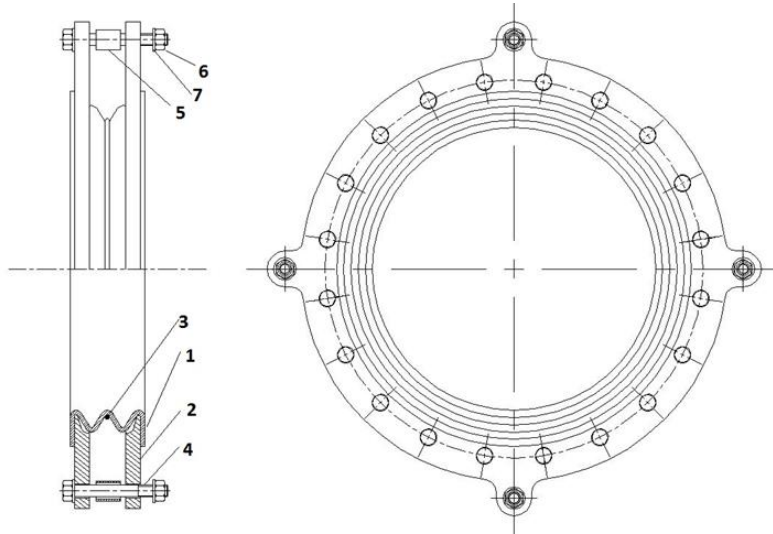

Vacuum Resistance bar (g)

Please consult ⁴⁾

⁴⁾ Suitable for vacuum with inner support rings

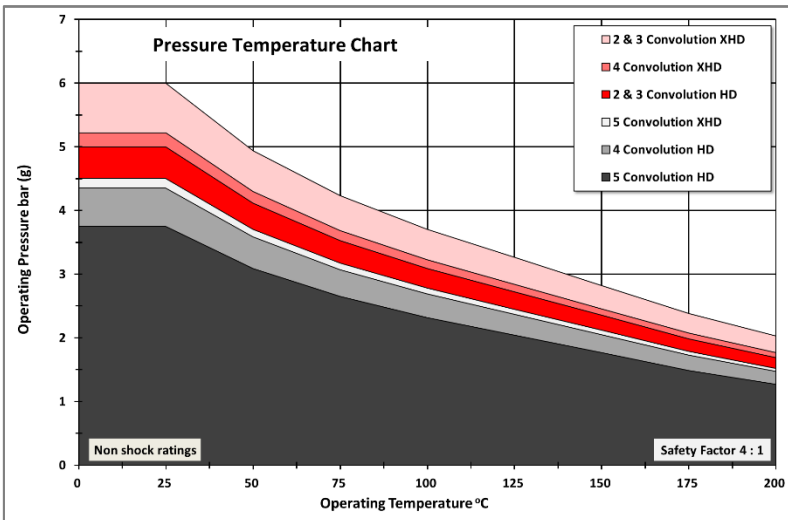

Flanges ASME Class 150 Series A

Raised Face Ø [mm]	857
Bolt Circle Ø [mm]	914
Flange-Ø max. [mm]	1117
Holes ³⁾	28 x 1 ¼" UNC
Thickness [mm]	27
Effective Area [m ²]	0,4717

Weight [kg]

FFB2	178
FFB3	181
FFB4	184
FFB5	187

Dimensions, Movements¹⁾ and Spring Rates²⁾

Type Convolution	Neutral Length [mm]	axial ± [mm]	lateral ± [mm]	angular ± degrees	Spring Rates ²⁾ 20 °C ±30 %			
					axial Comp. [N/mm]	axial Ext. [N/mm]	lateral [N/mm]	angular [Nm/°]
FFB2	160	25	11	2	3.340	2.590	6.145	145
FFB3	221	30	15	3	2.225	1.725	4.100	100
FFB4	282	39	19	3	1.670	1.294	3.076	73
FFB5	343	46	23	4	1.336	1.035	2.460	58

1) Combined movements call for considerations in common 2) Observe temperature dependence 3) Threaded flange holes are Standar

PTFE - Expansion Joint

Technical Data

FluoroFlow® Series FFB

32" ASME Class 150

Pos.	Component	Material	Standard
1	PTFE-Component	Multi-ply virgin PTFE or PTFE static-dissipating	ASTM D 4894 Type IV
2	Flanges	Carbon Steel BS1501-161-430A Ultra-High Temperature Paint	BS1501-161-430A
3	Root Rings	Stainless Steel 320S31 (316Ti) or Hastelloy 276 (2.4819)	SS320S31 (316Ti)
4	Tie Rods	Carbon Steel Grade 8.8 (Zinc plated)	EN ISO 898-1
5	Limit Sleeves	Stainless Steel ASTM A312 Gr. 304/304L	ASTM A312 Gr. 304/304L
6	Nuts	Carbon Steel Grade 8.8 (Zinc plated)	EN ISO 898-1
7	Washers	Carbon Steel Grade 8.8 (Zinc plated)	EN ISO 898-1

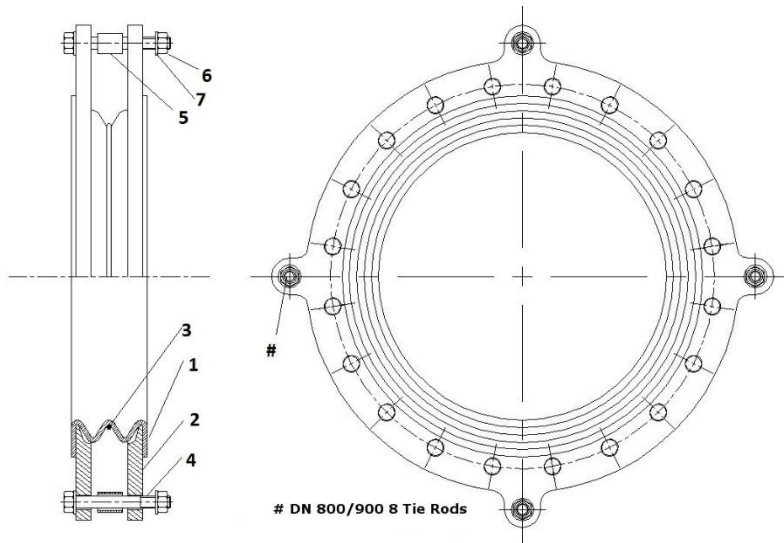

Vacuum Resistance bar (g)
On request ⁴⁾

⁴⁾ Suitable for vacuum with inner support rings

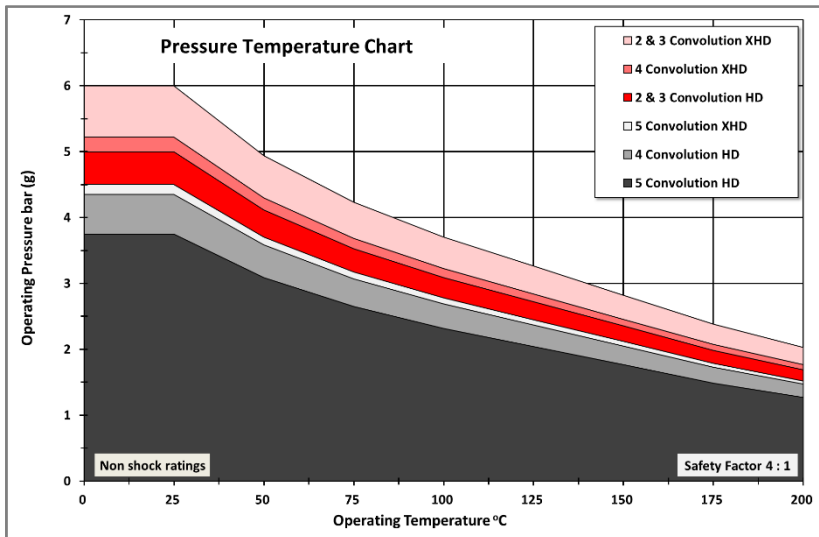

Flanges ASME Class 150 Series A	
Raised Face Ø [mm]	914
Bolt Circle Ø [mm]	978
Flange-Ø max. [mm]	1170
Holes ³⁾	28 x 1 1/2" UNC
Thickness [mm]	30
Effective Area [m ²]	0,5509

Weight [kg]	
FFB2	202
FFB3	206
FFB4	210
FFB5	214

Dimensions, Movements¹⁾ and Spring Rates²⁾

Type Convolution	Neutral Length [mm]	axial ± [mm]	lateral ± [mm]	angular ± degrees	Spring Rates ²⁾ 20 °C ±30 %			
					axial Comp. [N/mm]	axial Ext. [N/mm]	lateral [N/mm]	angular [Nm/°]
FFB2	160	25	11	2	3.560	2.750	6.550	153
FFB3	221	30	15	3	2.373	1.833	4.367	102
FFB4	282	39	19	3	1.780	1.375	3.275	77
FFB5	343	46	23	4	1.424	1.100	2.620	61

1) Combined movements call for considerations in common 2) Observe temperature dependence 3) Threaded flange holes are Standard

PTFE - Expansion Joint

Technical Data

FluoroFlow® Series FFB

36" ASME Class 150

Pos.	Component	Material	Standard
1	PTFE-Component	Multi-ply virgin PTFE or PTFE static-dissipating	ASTM D 4894 Type IV
2	Flanges	Carbon Steel BS1501-161-430A Ultra-High Temperature Paint	BS1501-161-430A
3	Root Rings	Stainless Steel 320S31 (316Ti) or Hastelloy 276 (2.4819)	SS 320S31 (316Ti)
4	Tie Rods	Carbon Steel Grade 8.8 (Zinc plated)	EN ISO 898-1
5	Limit Sleeves	Stainless Steel ASTM A312 Gr. 304/304L	ASTM A312 Gr. 304/304L
6	Nuts	Carbon Steel Grade 8.8 (Zinc plated)	EN ISO 898-1
7	Washers	Carbon Steel Grade 8.8 (Zinc plated)	EN ISO 898-1

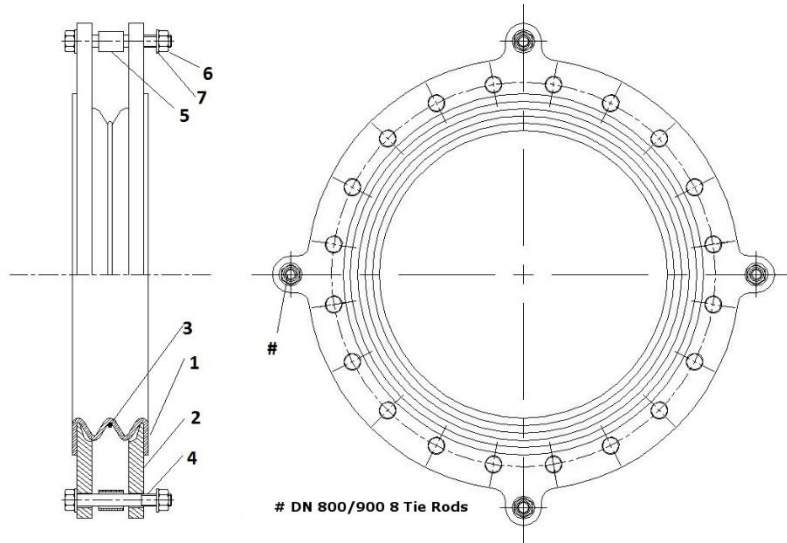

Vacuum Resistance bar (g)
On request ⁴⁾

⁴⁾ Suitable for vacuum with inner support rings

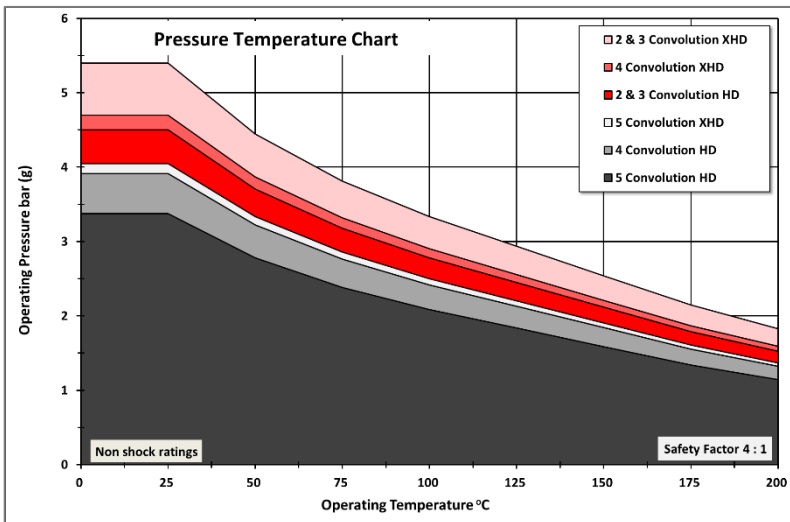

Flanges ASME Class 150 Series A	
Raised Face Ø [mm]	1022
Bolt Circle Ø [mm]	1086
Flange-Ø max. [mm]	1278
Holes ³⁾ [No. x Thread]	32 x 1 1/2" UNC
Thickness [mm]	45
Effective Area [m ²]	0,6702

Weight [kg]	
FFB2	310
FFB3	318
FFB4	326
FFB5	334

Dimensions, Movements¹⁾ and Spring Rates²⁾

Type Convolution	Neutral Length [mm]	axial ± [mm]	lateral ± [mm]	angular ± degrees	Spring Rates ²⁾ 20 °C / ± 50 %			
					axial Comp. [N/mm]	axial Ext. [N/mm]	lateral [N/mm]	angular [Nm/°]
FFB2	240	25	11	2	4.110	3.100	7.370	172
FFB3	307	32	15	3	2.740	2.067	4.914	114
FFB4	374	39	19	3	2.055	1.550	3.685	86
FFB5	441	46	23	4	1.644	1.240	2.948	68

1) Combined movements call for considerations in common 2) Observe temperature dependence 3) Threaded flange holes are Standard

PTFE - Expansion Joint

Technical Data

FluoroFlow® Series FFB

42" ASME Class 150

Pos.	Component	Material	Standard
1	PTFE-Component	Multi-ply virgin PTFE or PTFE static-dissipating	ASTM D 4894 Type IV
2	Flanges	Carbon Steel BS1501-161-430A Ultra-High Temperature Paint	BS1501-161-430A
3	Root Rings	Stainless Steel 320S31 (316Ti) or Hastelloy 276 (2.4819)	SS 320S31 (316Ti)
4	Tie Rods	Carbon Steel Grade 8.8 (Zinc plated)	EN ISO 898-1
5	Limit Sleeves	Stainless Steel ASTM A312 Gr. 304/304L	ASTM A312 Gr. 304/304L
6	Nuts	Carbon Steel Grade 8.8 (Zinc plated)	EN ISO 898-1
7	Washers	Carbon Steel Grade 8.8 (Zinc plated)	EN ISO 898-1

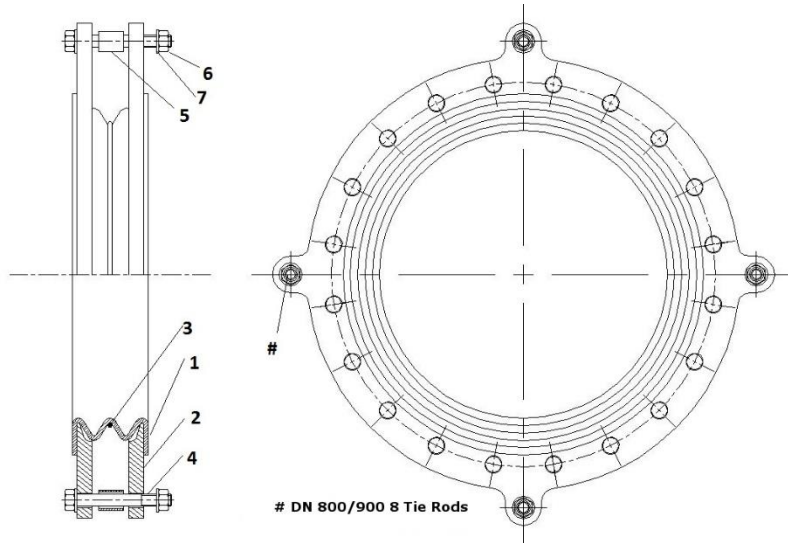

Vacuum Resistance bar (g)
On request ⁴⁾

⁴⁾ Suitable for vacuum with inner support rings

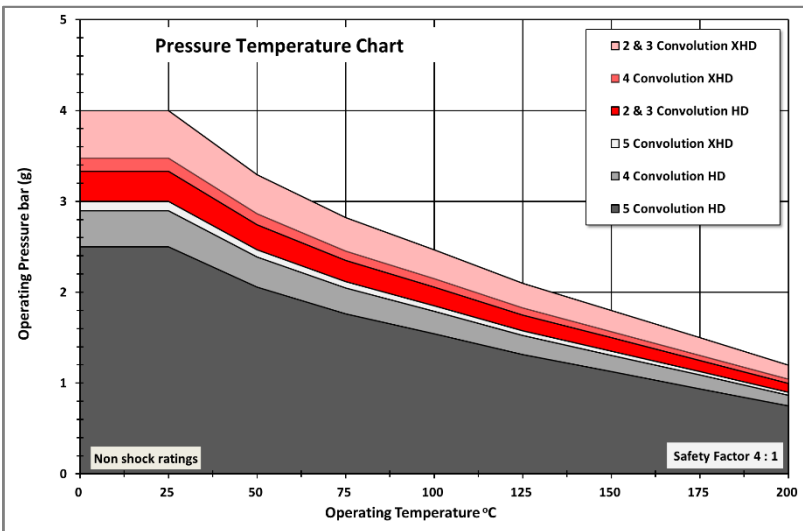

Flanges ASME Class 150 Series A	
Raised Face Ø [mm]	1194
Bolt Circle Ø [mm]	1257
Flange-Ø max. [mm]	1473
Holes ³⁾ [No. x Thread]	36 x 1 ½" UNC
Thickness [mm]	50
Effective Area [m ²]	1,07

Weight [kg]	
FFB2	512
FFB3	518
FFB4	524
FFB5	530

Dimensions, Movements¹⁾ and Spring Rates²⁾

Type Convolution	Neutral Length [mm]	axial ± [mm]	lateral ± [mm]	angular ± degrees	Spring Rates ²⁾ 20 °C / ± 50 %			
					axial Comp. [N/mm]	axial Ext. [N/mm]	lateral [N/mm]	angular [Nm/°]
FFB2	261	25	11	2	4.825	3.610	8.585	200
FFB3	326	32	15	2,5	3.217	2.407	5.725	132
FFB4	391	39	19	3	2.412	1.805	4.292	101
FFB5	456	46	23	3,5	1.930	1.444	3.434	79

1) Combined movements call for considerations in common 2) Observe temperature dependence 3) Threaded flange holes are Standard

Armoured PTFE - Expansion Joint

Technical Data

FluoroFlow® Series FFAB

1 1/2" NB – 20" NB 16/25 bar(g)

Armoured FluoroFlow® FFAB PTFE Bellows are manufactured from virgin HiPerFlon® PTFE and combined with multi-layered austenitic stainless-steel shell to provide high pressure performance outside the range of conventional PTFE-Expansion Joints. This range is designed to the EJMA international Standard.

The manufacturing technique is such that the PTFE and the steel shell are convoluted simultaneously to provide a uniform PTFE wall thickness throughout the product.

Pos.	Component	Material	Standard
1	PTFE-Liner	Paste extruded virgin PTFE or Multi-ply virgin PTFE	ASTM D 4895/D4894-IV
2	Outer Shell	1.4541 (SS 321) (Multi-layered)	EN 10028-7; EN 10217-7
3	Flanges	S235JR+N with Zinc Epoxy-Primer (grey)	EN 10025-2

Options

Pos.	Component	Material	Standard
1	PTFE-Liner	Static-Dissipating PTFE, paste extruded or Multi-ply	ASTM D 4895/D4894-IV
2	Outer Shell	Multi-layered Hastelloy and other exotic materials	DIN 17744; 17750; 17751
3	Flanges	1.4541 (SS 321), Low temperature steels, Hastelloy	EN 10028-7; EN 10217-7
4	Tie Rods (Option)	Carbon Steel Grade 8.8 (Zink plated)	EN ISO 898-1

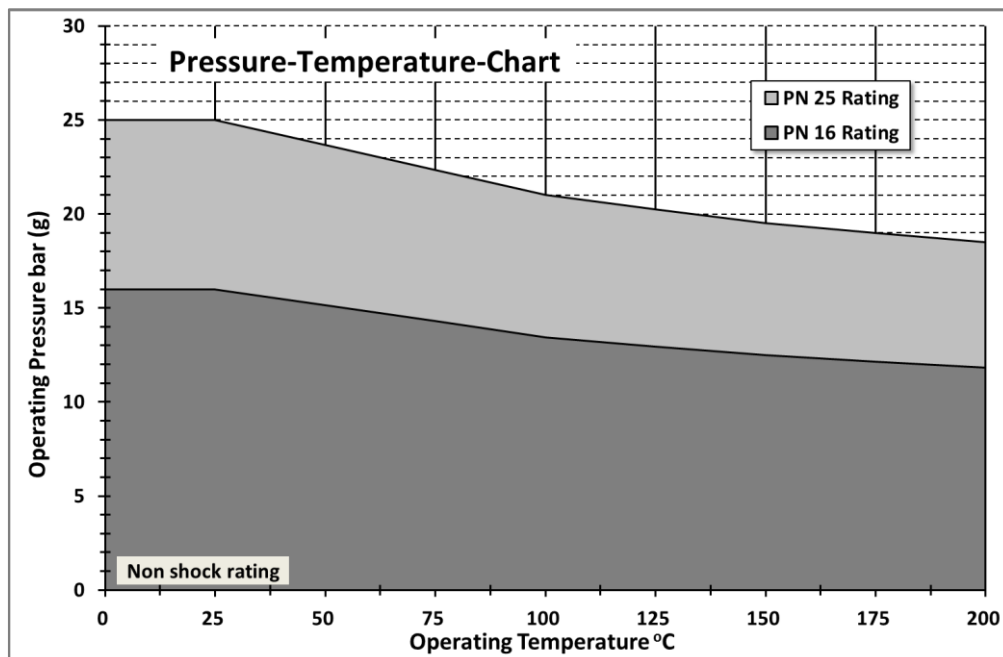
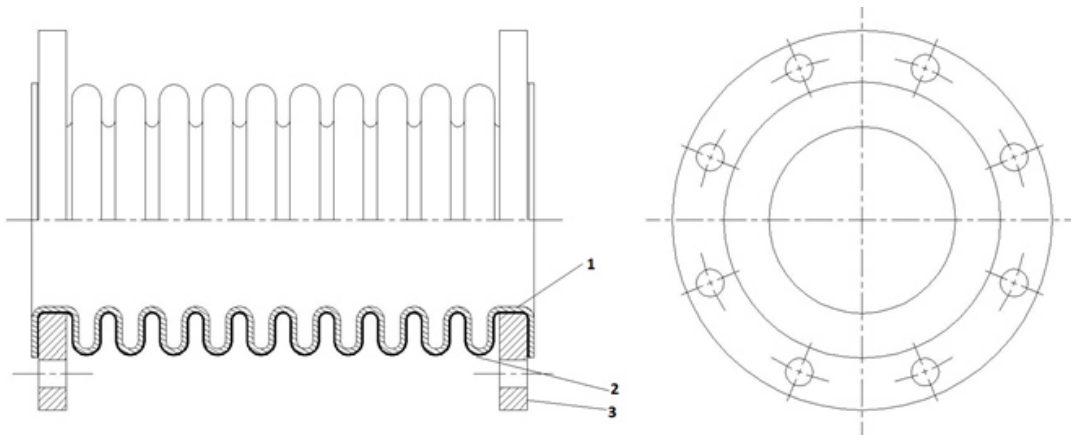

Armoured PTFE - Expansion Joint

Dimensions, Movements and Vacuum Resistance

Note that Standard flanges are rotating. Also tie rods are not supplied as part of the Standard product, they are an option.

NB	Ambient Rating bar (g)	Flange Type ASME Class	Neutral Length [mm]	axial ± [mm]	lateral ± [mm]	angular ± [Grad]	Spring Rate [N/mm] ± 30%	Effective Area [cm ²]	Weight [kg]	Vacuum 20 °C bar (g)	Vacuum 100 °C bar (g)	Vacuum 180 °C bar (g)
1 ½"	16	150	130	9	1	3	183	27,8	3,0	-1,0	-1,0	-1,0
	16		225	15	1	3	138	27,2	3,0			
	25	300	260	15	1	3	265	26,2	7,0			
2"	16	150	125	9	1	3	185	42,2	5,0			
	16		215	18	1	3	145	41,5	5,0			
	25	300	240	16	1	3	276	40,1	8,0			
2 ½"	16	150	135	9	1	2	200	59,0	7,0			
	16		215	18	1	2	214	57,0	8,0			
	25	300	230	16	1	2	274	56,6	12,0			
3"	16	150	130	10	1	2	216	85,1	8,0			
	16		220	19	1	2	202	84,0	10,0			
	25	300	225	16	1	2	245	83,1	15,0			
4"	16	150	160	10	1	2	300	138,3	12,0			
	16		260	21	1	2	179	137,0	13,0			
	25	300	220	17	1	2	280	135,8	25,0			
5"	16	150	175	11	1	2	390	200,8	14,0			
	16		270	23	1	2	237	199,0	16,0			
	25	300	300	20	1	2	356	196,3	35,0			
6"	16	150	165	11	1	1	530	279,0	17,0			
	16		300	26	1	1	216	280,0	17,0			
	25	300	295	20	1	1	407	274,6	43,0			
8"	16	150	180	12	1	1	707	448,0	27,0			
	16		325	33	1	1	303	445,5	30,0			
	25	300	230	13	1	1	750	443,4	61,0			
10"	16	150	200	14	1	1	896	677,0	38,0			
	16		330	34	1	1	376	677,0	40,0			
	25	300	330	27	1	1	624	672,0	92,0			
12"	16	150	195	17	1	1	792	939,0	59,0			
	16		350	40	1	1	338	939,0	61,0			
	25	300	345	33	1	1	597	926,3	136,0			
14"	16	150	175	18	1	1	1.026	1.108,0	78,0			
		315	44	1	1	484	1.108,0	80,0				
	25	n/a	315	35	1	1	661	1.097,0	n/a			
		300	335	35	1	1		1.097,0	170,0			
16"	16	150	335	48	1	1	445	1.437,0	114,0			
	25	n/a	330	37	1	1	859	1.432,0	n/a			
		300	350	37	1	1		1.432,0	209,0			
20"	16	150	220	25	1	1	1.067	2.159,0	144,0			
	25	300	300	32	1	1	1.095	2.175,0	290,0			

Notes:

Please note that Hastelloy is available for areas subject to stainless steel stress corrosion cracking such as HCl-Service. Longer and shorter lengths are available providing more or less axial travel. More lateral and angular movements are possible, please contact us.

FluoroFlow PTFE – Expansion Joint

Technical Data

Safety Shields

(1" - 42") ASME Class 150/300

	Material
Safety Shield	Glassfibre Coated PTFE Shield with FEP Window

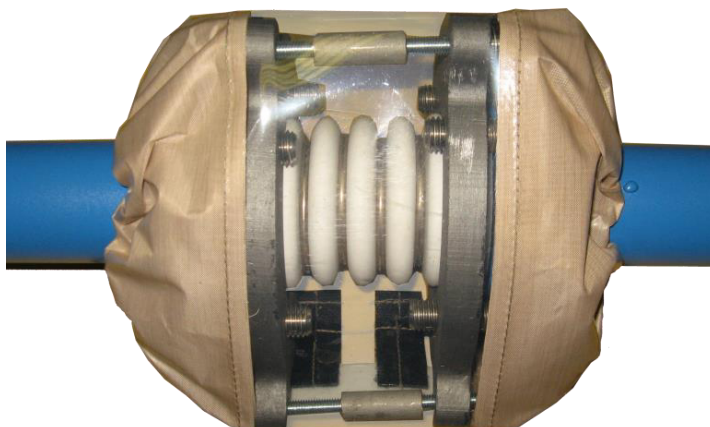

PTFE expansion joints, except for metal-reinforced designs or double-wall designs, have only one separating wall between the process medium and the outside atmosphere.

For the use of hazardous media, the European Pressure Equipment Directive (PED 2014/68/EU) and the BG Chemie (ZH 1/229) have recommendations that consider the use of suitable protective measures to be a priority.

The use of safety shields also contributes to risk minimization from the point of view of accident safety and the relevant accident prevention regulations (UVV) and as an effective safety measure to protect people and the environment. For all nominal widths of the FFB series of PTFE expansion joints with 2 - 5 convolutions, universal safety shields are

available in UV-resistant and high-temperature versions for applications up to 200°C, with suitability for flanges in DIN and ASME.

Fastening takes place without the use of additional tools by means of Velcro fasteners and corrosion-resistant cords on the adjacent line components.

The design with a window made of FEP allows visual leakage monitoring and thus ensures a comprehensive and always up-to-date assessment of the situation. The suitable design variant is only determined by the nominal width and the number of convolutions of the expansion joint.

Nominal Width	Product-Code			
	2 Convolutions	3 Convolutions	4 Convolutions	5 Convolutions
1"	SMD1"-2	SMD1"-3	SMD1"-4	SMD1"-5
1,5"	SMD1,5"-2	SMD1,5"-3	SMD1,5"-4	SMD1,5"-5
2"	SMD2"-2	SMD2"-3	SMD2"-4	SMD2"-5
2,5"	SMD2,5"-2	SMD2,5"-3	SMD2,5"-4	SMD2,5"-5
3"	SMD3"-2	SMD3"-3	SMD3"-4	SMD3"-5
4"	SMD4"-2	SMD4"-3	SMD4"-4	SMD4"-5
5"	SMD5"-2	SMD5"-3	SMD5"-4	SMD5"-5
6"	SMD6"-2	SMD6"-3	SMD6"-4	SMD6"-5
8"	SMD8"-2	SMD8"-3	SMD8"-4	SMD8"-5
10"	SMD10"-2	SMD10"-3	SMD10"-4	SMD10"-5
12"	SMD12"-2	SMD12"-3	SMD12"-4	SMD12"-5
14"	SMD14"-2	SMD14"-3	SMD14"-4	SMD14"-5
16"	SMD16"-2	SMD16"-3	SMD16"-4	SMD16"-5
18"	SMD18"-2	SMD18"-3	SMD18"-4	SMD18"-5
20"	SMD20"-2	SMD20"-3	SMD20"-4	SMD20"-5
24"	SMD24"-2	SMD24"-3	SMD24"-4	SMD24"-5
28"	SMD28"-2	SMD28"-3	SMD28"-4	SMD28"-5
30"	SMD30"-2	SMD30"-3	SMD30"-4	SMD30"-5
32"	SMD32"-2	SMD32"-3	SMD32"-4	SMD32"-5
36"	SMD36"-2	SMD26"-3	SMD36"-4	SMD36"-5
42"	SMD42"-2	SMD42"-3	SMD42"-4	SMD42"-5

Quality System Registration



IRISH
ENGINEERING
SERVICES

This is to certify that:

**Corrosion Resistant Products Limited,
Todmorden Road,
Littleborough,
OL15 9EG,
United Kingdom**

Has been granted Registration Certificate No: **ICAT000531588/PED/v1.0**

In respect of a Quality Management System which has been assessed and found to comply with the requirements of module **D1, E1 & H** of Annex III of the Pressure Equipment Directive 2014/68/EU for the following:

SCOPE:

The design and manufacture of fluoropolymer lined and metallic piping systems, associated piping equipment, PTFE bellows and sampling systems.

For Irish Engineering Services:

Nick Mayoh
2021.08.24
09:50:16 +01'00'

Certification Services Scheme Leader (ROI)



First registered: **20/12/2020**

Valid from: **24/08/2021**

Expiry: **23/08/2024**

- When module D or E is used in conjunction with module B see the latest issue of the Type Examination Schedule issued to the certificate holder.
- For pressure equipment in categories II, III and IV – permanent joining procedures and personnel shall be approved by an EU – 27 Notified Body/RTPO.
- For pressure equipment in categories III and IV – non-destructive testing personnel qualifications shall be approved by an EU – 27 Notified Body/RTPO.

Issued by:

Irish Engineering Services

RSA House, Dundrum Town Centre, Sandyford Road, Dublin 16, D16 FC92, Ireland



This certificate remains the property of Irish Engineering Services and is bound by the terms of the Certification Agreement.

Certificate of Registration

This is to certify that the Management System of:

Corrosion Resistant Products Limited

Todmorden Road, Littleborough, United Kingdom, OL15 9EG, United Kingdom

has been approved by Alcumus ISOQAR and is compliant with the requirements of:

ISO 9001: 2015



Certificate Number:	020-QMS-001
Initial Registration Date:	20 November 1992
Previous Expiry Date:	20 November 2019
Recertification Date:	1 October 2019
Re-issue Date:	3 October 2019
Current Expiry Date:	20 November 2022

Scope of Registration:

The development and manufacture of fluoropolymer lined and metallic piping systems, associated pipeline equipment and sampling systems. The stockholding and supply of third party valve and actuation products and associated pipeline equipment. Sub-contract fluoropolymer moulding and lining services.



Signed:
Steve Stubley, Technical Director
(on behalf of Alcumus ISOQAR)



This certificate will remain current subject to the company maintaining its system to the required standard. This will be monitored regularly by Alcumus ISOQAR. Further clarification regarding the scope of this certificate and the applicability of the relevant standards' requirement may be obtained by consulting Alcumus ISOQAR.

Client Corrosion Resistant Products Ltd
Contact Mr C Bullock
Report issue date 29th January 2013
Report number S107616R1V1/2013

Carbon Loaded PTFE Pipe Electrostatic Analysis

Checked by Gavin Rogers  Team Leader - IEH Laboratory	Reviewed by Stephen Rowe  Process Safety Specialist
For and on behalf of Chilworth Technology Limited	

Quote / Job Numbers: 107616 / 306344

© 2013, Chilworth Technology Limited

Report prepared by Christine Simmons

The Global Experts in Explosion and Process Safety

Chilworth Technology Limited
Beta House Southampton Science Park
Southampton SO16 7NS
United Kingdom

+44 (0)23 8076 0722
+44 (0)23 8076 7866
info@chilworthglobal.com
www.chilworth.co.uk

T
F
E
W

Chilworth
a DEKRA company

CONTENTS**PAGE NO.**

1. Introduction	3
2. Sample Information	4
3. Surface Resistivity (BS EN 61340-2-3)	5
3.1 Test Results for Carbon Loaded PTFE Pipe	6
4. Volume Resistivity (BS EN 61340-2-3)	7
4.1 Test Results for Carbon Loaded PTFE Pipe	9
5. Summary of Test Results and Recommendations	10
5.1 Summary of Test Data Obtained	10
5.2 Interpretation of Results and Recommendations	10

1. Introduction

This report contains test data for Corrosion Resistant Products Ltd regarding the electrostatic properties of Carbon Loaded PTFE Pipe. Specifically, the following work has been undertaken:

- Surface Resistivity Determination (at two relative humidities)
- Volume Resistivity Determination (at two relative humidities)

This work is in response to quotation number 107616. A formal hazard assessment of the process / plant has not been conducted by Chilworth Technology and the consequences of specific process deviations have not been examined¹.

Detailed characterisation of the material tested in this study is provided in Section 2 of this report (with results summarised in the conclusions section)^{2,3}. The following are the key dates for the work reported here:

Study initiation date*	:	11/01/2013
Start date of the experimental work	:	22/01/2013
Completion date of the experimental work	:	24/01/2013

* Sample, purchase order or last information receipt date, whichever is the latter.

The materials used in this assessment were supplied by Corrosion Resistant Products Ltd.

Name and address of client:

Corrosion Resistant Products Ltd
Todmorden Road
Littleborough
Lancashire
OL15 9EG
United Kingdom

¹ Process safety requires that all possible explosion, thermal stability and chemical reaction hazards are evaluated and that a suitable basis for safe operation is determined and implemented. Should the materials or processing conditions change then consideration should be given to re-assessment.

² A description of the test procedures together with full test results and information on their interpretation is given in the test sections of this report. The appendices provide background information on the subject matter. Chilworth Technology's Laboratories are GLP (Good Laboratory Practice) compliant and this study was carried out to the principles of GLP.

³ This report has been issued in digital format. In order to ensure that the integrity of the data is maintained, the signed hard copy (in the CTL archive) will be considered the source document and digital versions will be considered copies. All original test records are kept in a locked archive for a minimum of 10 years after the date of this report. Any remaining material will be stored for a minimum of 1 month after the issue date of this report.

2. Sample Information

Product name	Carbon Loaded PTFE Pipe
CTL sample reference	6713
Appearance	As received, the sample is observed to be a non-cylindrical, black pipe
Preparation	Sample tested as received
Internal Circumference (m)	0.231
External Circumference (m)	0.254
Wall Thickness (mm)	11.5

3. Surface Resistivity (BS EN 61340-2-3)

Test Objective and Information

The units of Surface Resistivity are Ω or Ω/\square . It describes the ability of a material to conduct electric charge across its surface and is the reciprocal of the electrical conductivity. For historical reasons the surface resistivity is generally used for solids and the Conductivity for liquids.

Method of Measurement

Due to the geometry of the test specimen it was not possible to use the standard test cell detailed within BSEN 61340-2-3 and thus the given formula for resistance and resistivity. Therefore the standard test cell was substituted for a bespoke test cell arrangement and modified resistivity formula (see below):

The Surface Resistivity, (in Ω/\square), is calculated using the following formula

$$\rho_s = \frac{R C}{l}$$

Where:

- P_s = Surface Resistivity (Ω/\square)
- R = Resistance (Ω)
- l = Length of sample tested (m)
- C = Circumference tested (m)

The measurement cells used comprised of two opposing, metal, band electrodes that were securely tightened around the pipes outer circumference and spaced 10 mm apart. One a current / resistance measuring electrode, the other a voltage application electrode.

The electrode assemblies described above are positioned onto the approximate centre of the specimen or at least 10mm away from the edges and connected to the test instrumentation.

The equipment is energised at 10 V, if the calculated resistance is less than $1.0 \times 10^6 \Omega$ then this result is recorded and the procedure repeated at various areas of the specimen or on fresh material if available. If the calculated resistance is equal to or greater than 1.0×10^6 then the procedure is repeated using 100 V.

The measured or calculated resistance (applied voltage / measured current) is then substituted into the above formula to present a surface resistivity value, the average of all areas tested shall be given as the final value of resistivity.

Most materials also adsorb atmospheric water to a lesser or greater extent, which for many materials has a dramatic effect on the surface resistivity. The test is therefore carried out at ambient relative humidity (RH $50 \pm 5 \%$) and in dry conditions (RH $15 \pm 2 \%$), in both cases the sample is conditioned at the stated relative humidity for 24 hours prior to testing.

Interpretation of results

By definition as stated in CENELEC CLC/TR 50404:2003 a material would no longer be regarded as static dissipative when the surface resistivity is found to be greater than $10^{11}\Omega/\square$.

It is good practice to minimise the use of non-conductive materials in hazardous areas. Materials may be grouped by their resistivity as follows:

Definition	Surface Resistivity (Ω/\square)	Volume Resistivity (Ωm)	Examples
Conducting	-	$< 10^4$	Metal
Dissipative	$< 10^{11}$	$10^4 - 10^9$	some organic materials
Insulating	$>10^{11}$	$> 10^9$	synthetic polymers

3.1 Test Results for Carbon Loaded PTFE Pipe

Date : 22/01/2013 – 24/01/2013
 Operator : G. Rogers
 Preparation : Sample tested as received

RH (%)	Temperature ($^{\circ}C$)	Surface resistivity (Ω/\square)
50	20	3.3×10^7
15	20	3.8×10^7

Table 3.1 : Full Test Results

Voltage (V)	@ 50% RH			@ 15% RH		
	Current (A)	Resistance (Ω)	Resistivity (Ω/\square)	Current (A)	Resistance (Ω)	Resistivity (Ω/\square)
10	9.0×10^{-7}	1.1×10^7	$> 1.0 \times 10^6$	Resistivity assumed to be $> 1.0 \times 10^6$		
100	-	1.3×10^6	3.3×10^7	-	1.4×10^6	3.6×10^7
100	-	1.5×10^6	3.8×10^7	-	1.5×10^6	3.8×10^7
100	-	1.1×10^6	2.8×10^7	-	1.6×10^6	4.1×10^7

An insulation tester was used measuring direct resistance when using 100 V.

The results obtained above indicate that the sample of Carbon Loaded PTFE Pipe is static dissipative

4. Volume Resistivity (BS EN 61340-2-3)

Test Objective and Information

The ratio of a d.c. field strength (V/m) and the steady-state current density (A/m²) within the material. In practice, it is equivalent to the volume resistance of a cube with unit length, having the electrodes at two opposite surfaces.

The units of Volume Resistivity are Ωm. It describes the ability of a material to conduct electric charge and is the reciprocal of the electrical conductivity. For historical reasons the Volume Resistivity is generally used for solids and the Conductivity for liquids.

Method of Measurement

Due to the geometry of the test specimen it was not possible to use the standard test cell detailed within BSEN 61340-2-3 and thus the given formula for resistance and resistivity. Therefore the standard test cell was substituted for a bespoke test cell arrangement and modified resistivity formula (see below):

The Volume Resistivity, (in Ωm), is calculated using the following formula

$$P_V \approx R \frac{C_i + C_o}{2} \frac{w}{d} = RK_V$$

Where:

P_V	= Volume Resistivity (Ωm)
R	= Resistance (Ω)
d	= Thickness of sample tested (m)
C_i	= Inner circumference (m)
C_o	= Outer circumference (m)
w	= Width of narrowest electrode (m)
K_V	= Cell Constant

The measurement cells used comprised of a metal, band electrode that was securely tightened around the pipes outer circumference and an internal sprung electrode that was inserted into the pipes void, making good contact with the pipes internal surface apart and directly below the outer metal electrode. One used as a current / resistance measuring electrode, the other a voltage application electrode.

The electrode assemblies described above are positioned onto the approximate centre of the specimen or at least 10mm away from the edges and connected to the test instrumentation.

The equipment is energised at 10 V, if the calculated resistance is less than $1.0 \times 10^6 \Omega$ then this result is recorded and the procedure repeated at various areas of the specimen. If the calculated resistance is equal to or greater than 1.0×10^6 then the procedure is repeated using 100 V.

The calculated resistance (applied voltage / measured current) is then substituted into the above formula to present a volume resistance value, the average of all areas tested shall be given as the final value of resistivity.

Most materials also adsorb atmospheric water to a lesser or greater extent, which for many materials has a dramatic effect on the surface resistivity. The test is therefore carried out at ambient relative humidity ($RH 50 \pm 5 \%$) and in dry conditions ($RH 15 \pm 2 \%$), in both cases the sample is conditioned at the stated relative humidity for 24 hours prior to testing.

Interpretation of results

By definition as stated in CENELEC CLC/TR 50404:2003 a material would no longer be regarded as static dissipative when the volume resistivity is found to be greater than $10^9 \Omega\text{m}$.

It is good practice to minimise the use of non-conductive materials in hazardous areas. Materials may be grouped by their resistivity as follows:

Definition	Surface Resistivity (Ω/\square)	Volume Resistivity (Ωm)	Examples
Conducting	-	$< 10^4$	Metal
Dissipative	$< 10^{11}$	$10^4 - 10^9$	some organic materials
Insulating	$> 10^{11}$	$> 10^9$	synthetic polymers

4.1 Test Results for Carbon Loaded PTFE Pipe

Date : 22/01/2013 – 24/01/2013
 Operator : G. Rogers
 Preparation : Sample tested as received

RH (%)	Temperature ($^{\circ}\text{C}$)	Volume resistivity (Ωm)
50	20	2.5×10^7
15	20	3.0×10^7

Table 4.1 : Full Test Results

Voltage (V)	@ 50% RH			@ 15% RH		
	Current (A)	Resistance (Ω)	Resistivity (Ωm)	Current (A)	Resistance (Ω)	Resistivity (Ωm)
10	1.5×10^{-8}	6.7×10^8	$> 1.0 \times 10^6$	Resistivity assumed to be $> 1.0 \times 10^6$		
100	-	3.1×10^7	2.7×10^7	-	3.5×10^7	3.0×10^7
100	-	2.6×10^7	2.3×10^7	-	3.1×10^7	2.7×10^7
100	-	2.8×10^7	2.4×10^7	-	3.8×10^7	3.3×10^7

An insulation tester was used measuring direct resistance when using 100 V.

The results obtained above indicate that the sample of Carbon Loaded PTFE Pipe is static dissipative.

5. Summary of Test Results and Recommendations

5.1 Summary of Test Data Obtained

The results of testing completed on Carbon Loaded PTFE Pipe are summarised in Table 5.1.

Table 5.1: Summary of Results

Parameter	Test Results
Electrostatic Properties	
Surface Resistivity Determination (Ω/\square)	
50% RH	3.3×10^7
15% RH	3.8×10^7
Volume Resistivity Determination (Ωm)	
50% RH	2.5×10^7
15% RH	3.0×10^7

The results of testing are highly dependent on the composition and physical nature of the sample. For this reason, any change in manufacturing / handling procedures or composition should be accompanied by a review of the relevant data.

Chilworth Technology Ltd would be pleased to provide specific advice, including interpretation and application of experimental data. Site visits to discuss operational safety or to perform plant inspections and measurements can be arranged on request.

5.2 Interpretation of Results and Recommendations

Both surface and volume resistivity show that this pipe should be considered to be static dissipative.

This guidance is based purely upon the data collected from the current study and therefore may not encompass all factors which are necessary in order to fully support your chosen Basis of Safety for processing the material. The test work should be supplemented with a detailed hazard and risk assessment (incorporating a hazardous area classification study), definition and implementation of a Basis of Safety and control measures, and continuing auditing to ensure that places where the material is processed remain safe. If further clarification, or support in any of these activities, is required, Chilworth Technology would be pleased to assist.



Todmorden Road
Littleborough
OL15 9EG
Tel: +44(0)1706 756400
Fax: +44(0)1706 379567
web: www.crp.co.uk
e-mail: enquiry@crp.co.uk
Tuesday, 14th June 2022

Declaration of Compliance for Food Contact Materials

Virgin PTFE and PFA Resins

Corrosion Resistant Products (CRP) declares that the composition of Virgin Polytetrafluoroethylene (PTFE) and Virgin Perfluoroalkoxy (PFA) resins used in the manufacture of their products has the following status relative to food contact regulations.

European Union

Compliance with European Regulation EU No.10/2011 as amended. We can confirm that the raw materials and the subsequent products manufactured have been produced according to a quality management system which complies with the requirements of European Regulation EC No.2023/2006 on good manufacturing practice for materials and articles intended to come into contact with food.

United States of America

Compliance with U.S. FDA 21 CFR 177.1550 (a)(2) and (b) Perfluorocarbon resins.

Static-Dissipating PTFE Resin

CRP also declares that the high purity furnace black used in the manufacture of static-dissipating PTFE products has the following status relative to food contact regulations.

European Union

Compliance with European Regulation EU No.10/2011 as amended. We can confirm that the raw materials and the subsequent products manufactured have been produced according to a quality management system which complies with the requirements of European Regulation EC No.2023/2006 on good manufacturing practice for materials and articles intended to come into contact with food.

United States of America

Compliance with U.S. FDA 21 CFR 178.3297 Colorants for polymers. We can confirm that the formulated carbon black levels do not exceed 2.5% by weight.

Graham Price, Managing Director.

